

Алматы (7273)495-231
Ангарск (3955)60-70-56
Архангельск (8182)63-90-72
Астрахань (8512)99-46-04
Барнаул (3852)73-04-60
Белгород (4722)40-23-64
Благовещенск (4162)22-76-07
Брянск (4832)59-03-52
Владивосток (423)249-28-31
Владикавказ (8672)28-90-48
Владимир (4922)49-43-18
Волгоград (844)278-03-48
Вологда (8172)26-41-59
Воронеж (473)204-51-73
Екатеринбург (343)384-55-89

Иваново (4932)77-34-06
Ижевск (3412)26-03-58
Иркутск (395)279-98-46
Казань (843)206-01-48
Калининград (4012)72-03-81
Калуга (4842)92-23-67
Кемерово (3842)65-04-62
Киров (8332)68-02-04
Коломна (4966)23-41-49
Кострома (4942)77-07-48
Краснодар (861)203-40-90
Красноярск (391)204-63-61
Курск (4712)77-13-04
Курган (3522)50-90-47
Липецк (4742)52-20-81

Магнитогорск (3519)55-03-13
Москва (495)268-04-70
Мурманск (8152)59-64-93
Набережные Челны (8552)20-53-41
Нижний Новгород (831)429-08-12
Новокузнецк (3843)20-46-81
Новоуральск (3496)41-32-12
Новосибирск (383)227-86-73
Омск (3812)21-46-40
Орел (4862)44-53-42
Оренбург (3532)37-68-04
Пенза (8412)22-31-16
Петрозаводск (8142)55-98-37
Псков (8112)59-10-37
Пермь (342)205-81-47

Ростов-на-Дону (863)308-18-15
Рязань (4912)46-61-64
Самара (846)206-03-16
Санкт-Петербург (812)309-46-40
Саратов (845)249-38-78
Севастополь (8692)22-31-93
Саранск (8342)22-96-24
Симферополь (3652)67-13-56
Смоленск (4812)29-41-54
Сочи (862)225-72-31
Ставрополь (8652)20-65-13
Сургут (3462)77-98-35
Сыктывкар (8212)25-95-17
Тамбов (4752)50-40-97
Тверь (4822)63-31-35

Тольятти (8482)63-91-07
Томск (3822)98-41-53
Тула (4872)33-79-87
Тюмень (3452)66-21-18
Ульяновск (8422)24-23-59
Улан-Удэ (3012)59-97-51
Уфа (347)229-48-12
Хабаровск (4212)92-98-04
Чебоксары (8352)28-53-07
Челябинск (351)202-03-61
Череповец (8202)49-02-64
Чита (3022)38-34-83
Якутск (4112)23-90-97
Ярославль (4852)69-52-93

Россия +7(495)268-04-70

Казахстан +7(7172)727-132

Киргизия +996(312)96-26-47

<https://amiad.nt-rt.ru> || afv@nt-rt.ru

Mesh filters SAF-X, SAF-X-3000, SAF-X-4500



SAF X Filters

SERIAL NUMBER

ORDER NUMBER

CATALOG NUMBER

TESTED BY

NOTE: This Document Contains Amiad Confidential Information. Copying and Distributing This Document are Strictly Prohibited.

Contents

1. Disclaimer	3
2. Safety Instructions	4
3. Technical Specifications SAF-X 1500	7
4. GA Drawing – 3” SAF-X 1500 (available also with 2” and 4” connections)	8
5. Technical Specifications SAF-X 3000	9
6. GA Drawing – 4” SAF-X 3000 (available also with 3” and 6” connections)	10
7. Technical Specifications SAF-X 4500	11
8. GA Drawing – 6” SAF-X 4500 (available also with 4” and 8” connections)	12
9. Description of Filter Operation	13
10. Installation Instructions	15
11. Commissioning	18
12. Part Schedule	20
13. Spare parts Kits	24
14. Parts Drawings	25
15. Maintenance	30
16. Troubleshooting	37
17. Amiad Limited Warranty	38

2. Safety Instructions

Applicable local or national safety regulations and rules for the prevention of accidents must be applied in all work procedures in addition to the following instructions.

General Safety Instructions

- Amiad filtration products always operate as components in a larger system. It is essential for the system designers, installers, and operators to comply with all the relevant safety standards.
- Prior to installation, operation, maintenance, or any other type of action carried out on the filter, carefully read the safety, installation and operation instructions.
- During installation, operation or maintenance of the filter all conventional safety instructions should be observed in order to avoid danger to the workers, the public or to property in the vicinity.
- Please note: The filter enters into a flushing mode automatically, without prior warning.
- No change or modification to the equipment is permitted without a written notification given in advance by the manufacturer or by its representative, on the manufacturer's behalf.
- Always observe standard safety instructions and good engineering practices whilst working in the filter's vicinity.
- Use the filter only for its intended use as designed by Amiad, any misuse of the filter may lead to undesired damage and may affect your warranty coverage. Please consult with Amiad prior to any non-regular use of this equipment.

Installation

- Install the filter according to the detailed Installation Instructions provided with the filter by the manufacturer and according to the description given in this manual.
- Make sure to leave enough clearance to enable easy access for future treatments and safe maintenance operations.
- The user should arrange suitable lighting at the area of the filter to enable good visibility and safe maintenance.
- The user should arrange suitable platforms, ladders, and safety barriers to enable easy and safe access to the filter without climbing on pipes and other equipment. The user should verify that any platform, barrier, ladder or other such equipment is built, installed and used in accordance with the relevant local authorized standards.
- Check and re-tighten all bolts during commissioning and after the first week of operation.
- Use only appropriate standard tools and equipment operated by qualified operators when installing, operating and maintaining the filter.
- When installation is required in hazardous environment sites, underground or high above ground, make sure that the site design and the auxiliary equipment are appropriate and that installation procedures are carried out in accordance with the relevant standards and regulations.
- Ensure walking areas about the installation are slip free when wet.

Shipment and Transporting

- Shipping and transporting the filter must be done in a safe and stable manner and in accordance with the relevant standards and regulations.
- For shipping, lifting, and positioning the filter, use only approved lifting equipment and authorized employees and contractors.

Electricity

- Electric wiring should be performed by an authorized electrician only, using standardized and approved components.
- Install a lockable main power cut-off switch close to the control panel.
- If due to site constraints, the control panel is installed without a clear line-of sight of the filter, an additional lockable power disconnect cut-off switch should be installed near each filter unit.
- Installation of the filter should be performed so as to avoid direct water splashing on the electrical components or on the control panel.

Pneumatics

- Install a lockable main cut-off switch, featured with a pressure release mechanism, on the compressed air supply line close to the control panel.
- If the control panel is installed far away and there is no eye contact with the filter, a lockable compressed air cut-off switch, featured with a pressure release mechanism, should be installed near each filter unit.
- The user should make sure that the compressed air supplied to the filter never exceeds the maximum designated pressure for this filter. An air-pressure reduction valve should be installed on the compressed air supply line upstream of the filter's pneumatic inlet port.

Hydraulics

- Extra safety devices should be installed on hot water applications to avoid skin burn danger.
- The user should install a manual Water Cut-off Valve next to the filter's inlet port.
- In cases where the downstream piping network downstream of the filter is pressurized an additional manual Water Cut-off Valve should be installed next to the filter outlet port.
- The user should make sure that the system includes a Pressure Release / Drainage Valve to enable release of residual pressure prior to any maintenance procedure performed on the filter.
- The user should make sure that the filter is never exposed to water pressure exceeding the maximum designated pressure for this filter, if needed a Pressure Reduction Valve should be installed upstream of the filter's water inlet port.
- Please note that the maximum working pressure indicated at the filter's specifications table includes the pressure caused by fluid hammer and pressure surge effects.

Civil Engineering

- Make sure that the filter installation is done by a qualified technician.
- Make sure that any civil engineering work at the installation site such as construction, lifting, welding, etc. is done by qualified workers / technicians / contractors and in accordance with the relevant local standards.
- While using lifting equipment, make sure that the filter or the lifted part is chained securely and in a safe manner.
- Do not leave lifted equipment if there is no necessity. Avoid working below lifted equipment.
- Wear a safety helmet while using lifting equipment.
- Make sure that the flooring is sloped for drainage and to avoid accumulation of liquids.

Commissioning

- Carefully read the Commissioning and the First Start-up Operation instructions prior to any attempt to operate the filter.
- To achieve maximum performance and smooth operation of the filter it is crucial to perform the Startup and First Operation procedures exactly as described in this manual.
- Commissioning the filter should be done by an authorized Amiad technician, do not attempt to commission the filter unaccompanied since this may lead to undesired damage and may affect your warranty coverage.

Operation and Control

- Do not operate the filter before reading carefully and being familiar with its operation instructions.
- Observe the safety stickers on the filter and never perform any operation contradicting the instructions given.
- Never operate or use the filter for purposes other than its original design and operational envelope.

Maintenance

Before any maintenance or non-regular operation please read the following:

- Servicing the filter should be done only by technicians authorized by Amiad.
- Disconnect the filter from the power supply and lock the Main Power Switch.
- Disconnect the compressed air supply, release the residual pressure, and lock the Pneumatics Main Valve.
- Disconnect the filter from the water system by closing and securing the Manual Inlet Valve. In cases where the downstream piping network is pressurized, close and secure the Manual Outlet Valve also.
- Release the residual water pressure by opening the Pressure Release / Drainage Valve.
- Empty the filter by opening the Drainage Valve.
- In hot water systems wait till the filter components cool off to a safe temperature.
- Place warning signs around the work area as required by the local standards and procedures.
- Inspect the filter's safety stickers and replace any damaged or faded sticker.

Mechanical

- When working on the filter use only appropriate standard tools.
- Always open and close valves slowly and gradually.
- Remove grease and fat material residues to avoid slipping.
- Before disconnecting the filter from the water supply, electricity, and pneumatics and before releasing the filter's residual pressure do NOT:
 - loosen or unscrew bolts
 - remove any protection cover
 - open any service port flange
- Avoid splashing and water leakage so as to minimize slippage, electrification or damage to the equipment, caused by moisture.
- While using lifting equipment, make sure that the filter or the lifted part is chained securely and in a safe manner.
- Do not leave lifted equipment if there is no necessity. Avoid working below lifted equipment.
- Wear a safety helmet, goggles, gloves, and any other personal safety equipment required by the local standards and regulations.
- Human entry into a filter must be done in accordance with the relevant local safety instructions, standards and regulations for working in hazardous environment.
- Manual cleaning of filter media using high water pressure or steam should be performed in accordance with the cleaning system instructions, the local standards, and regulations and without endangering the operator or the vicinity.
- Manual cleaning of filter element using acid or other chemical agents should be performed in accordance with the relevant material safety instructions, the local standards, and regulations and without endangering the operator or his vicinity.

Before Returning to Regular Operation

- Re-assemble any protection covers or protection mechanisms removed during service or maintenance operations.
- Make sure that all the tools, ladders, lifting devices, etc. used during the maintenance procedures are taken away from the filter area and stored.
- In order to return the filter to regular operation, follow the First Start-up Operation instructions as detailed in your user manual.
- For filters used in potable water systems it is required to disinfect the filter according to the local water authority standards and regulations before putting it back to service.

3. Technical Specifications SAF-X 1500

General

Maximum flow rate	80 m ³ /hr	352 gpm	Consult manufacturer for optimum flow depending on filtration degree & water quality.
Design Pressure	10 bar(g)	150 psi	
Min. Operating pressure	2.0 bar(g)	30 psi	Pressure is critical during the flushing cycle. Consult manufacturer for the required values according to filtration degree and operation conditions.
Temperature Min / Max	4 ^o / 50 ^o C	39.2 ^o / 122 ^o F	
Filtration area	1500 cm ²	233 in ²	
Inlet/Outlet diameter	50,80,100 mm	2", 3", 4"	Flange standards as per request.
Filter housing	250 mm	10"	Epoxy-coated steel, or other on request.
Weight: empty / Operation	50 mm = 114/174 Kg 80 mm = 115/175 Kg 100 mm = 118/178 Kg	2" = 251/383 lb. 3" = 253/385 lb. 4" = 260/392 lb.	

Flushing Data

Exhaust valve	50 mm	2"	
Flushing cycle time	20 seconds	20 seconds	
Reject volume per cycle	39 liter	10 gallon	STD Nozzle at 2.5 bar/35 psi
Minimum flow for flushing	7 m ³ /h	31 gpm	

Control and Electricity

Control voltage	120 & 24 VAC or 24VDC
Electric motor	1/4 HP (0.18 kW) 50/60 Hz,
Rated operation Voltage	3 phase 208/230/380/400/415/460/575 Volt 50/60 Hz Single phase, 120/240 Volt 50/60 Hz
Current consumption	0.6 Amp. (see electrical diagram for specific values)

Construction Materials

Filter Housing and Lid	Epoxy-coated carbon steel 37-2 (Stainless Steel 316 available on request).
Screens	Stainless Steel 316
Cleaning mechanism	Stainless Steel 316, POM, PVC
Exhaust valve	Epoxy-coated cast iron, Natural Rubber
Seals	Synthetic Rubber
Control	Aluminum, Brass, Stainless Steel, PVC

Standard Filtration Degrees

	Stainless Steel Weave-wire Screen											
micron	800	500	300	200	130	100	80	50	40	30	20	10
mm	0.8	0.5	0.3	0.2	0.13	0.1	0.08	0.05	0.04	0.0	0.02	0.01

4. GA Drawing – 3” SAF-X 1500 (available also with 2” and 4” connections)

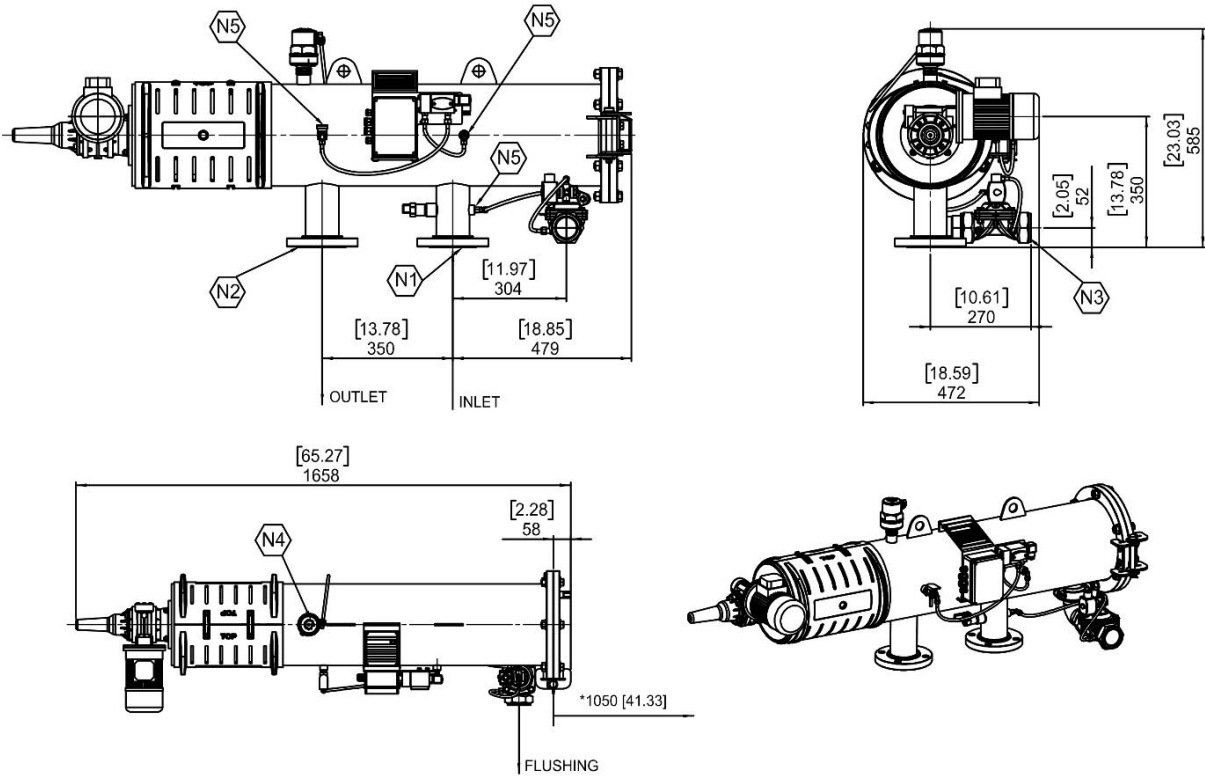

NOZZLES LIST						
CODE	QTY.	DN	CLASS	PIPE	CONNECTION	SERVICE
N1	1	3"	BY DEMAND	VARY	S.O.R.F	INLET
N2	1	3"	BY DEMAND		S.O.R.F	OUTLET
N3	1	2"	BSP		Thread (F)	FLUSHING
N4	2	3/4"	BSP		Thread (F)	Drain / Air release
N5	3	1/4"	BSP		Thread (F)	INSTRUMENTATION

CONSTRUCTION		
Materials For Filter Vessel		
Housing / Lid: C/ST		
Flanges: See Class		
DESIGN CRITERIA		
Design Code	EN-13445	
Design Pressure	10 Bar [145psi]	
Design Temperature	50°C [122 F]	
Volume	60 L / 16 Gallons	
TOTAL WEIGHT		
	KG	LB
Empty	115	253
Operating	164	362
Lid	11	24

* APPROX. LENGTH REQUIRED FOR MAINTENANCE.
DIMENSIONS ARE IN MM [INCH]

5. Technical Specifications SAF-X 3000

General

Maximum flow rate	160 m ³ /hr	700 gpm	Consult manufacturer for optimum flow depending on filtration degree & water quality.
Design Pressure	10 bar(g)	150 psi	
Min. Operating pressure	2.0 bar(g)	30 psi	Pressure is critical during the flushing cycle. Consult manufacturer for the required values according to filtration degree and operation conditions.
Temperature Min / Max	4 ^o / 50°C	39.2 ^o / 122°F	
Filtration area	3000 cm ²	465 in ²	
Inlet/Outlet diameter	80,100,150 mm	3", 4", 6"	Flange standards as per request.
Filter housing	250 mm	10"	Epoxy-coated steel, or other on request.
Weight: empty / Operation	80 mm = 118/188 Kg 100 mm = 121/191 Kg 150 mm = 126/196 Kg	3" = 260/414 lb. 4" = 266/420 lb. 6" = 277/431 lb.	

Flushing Data

Exhaust valve	50 mm	2"	
Flushing cycle time	20 seconds	20 seconds	
Reject volume per cycle	78 liter	20 gallon	STD Nozzle at 2.5 bar/35 psi
Minimum flow for flushing	14 m3/h	62 gpm	

Control and Electricity

Control voltage	120 & 24 VAC or 24VDC
Electric motor	1/4 HP (0.18 kW) 50/60 Hz,
Rated operation Voltage	3 phase 208/230/380/400/415/460/575 Volt 50/60 Hz Single phase, 120/240 Volt 50/60 Hz
Current consumption	0.6 Amp. (see electrical diagram for specific values)

Construction Materials

Filter Housing and Lid	Epoxy-coated carbon steel 37-2 (Stainless Steel 316 available on request).
Screens	Stainless Steel 316
Cleaning mechanism	Stainless Steel 316, POM, PVC
Exhaust valve	Epoxy-coated cast iron, Natural Rubber
Seals	Synthetic Rubber
Control	Aluminum, Brass, Stainless Steel, PVC

Standard Filtration Degrees

	Stainless Steel Weave-wire Screen											
micron	800	500	300	200	130	100	80	50	40	30	20	10
mm	0.8	0.5	0.3	0.2	0.13	0.1	0.08	0.05	0.04	0.0	0.02	0.01

6. GA Drawing – 4" SAF-X 3000 (available also with 3" and 6" connections)

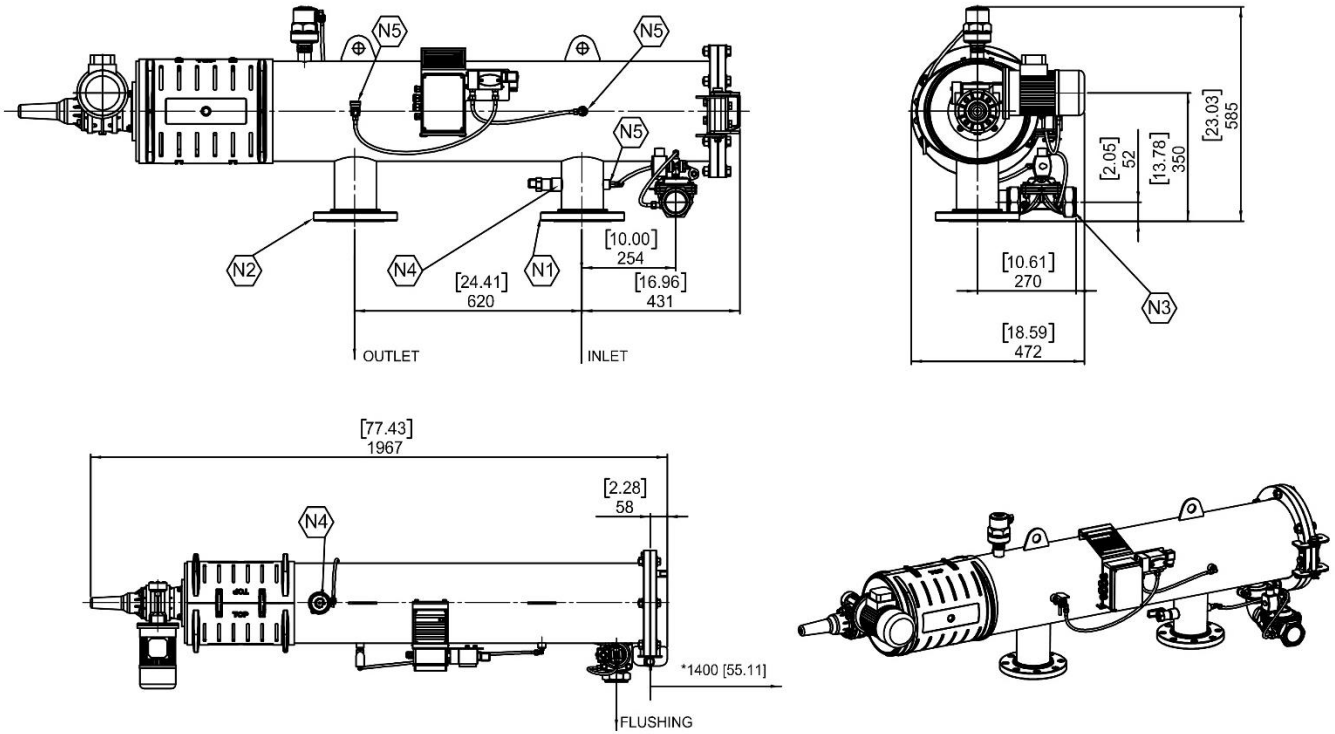

NOZZLES LIST						
CODE	QTY.	DN	CLASS	PIPE	CONNECTION	SERVICE
N1	1	4"	BY DEMAND	VARY	S.O.R.F	INLET
N2	1	4"	BY DEMAND		S.O.R.F	OUTLET
N3	1	2"	BSP		Thread (F)	FLUSHING
N4	2	3/4"	BSP		Thread (F)	Drain / Air release
N5	3	1/4"	BSP		Thread (F)	INSTRUMENTATION

CONSTRUCTION		
Materials For Filter Vessel		
Housing / Lid: C/ST		
Flanges: See Class		
DESIGN CRITERIA		
Design Code	EN-13445	
Design Pressure	10 Bar [145psi]	
Design Temperature	50° C [°122 F]	
Volume	60 L / 16 Gallons	
TOTAL WEIGHT		
	KG	LB
Empty	121	267
Operating	181	399
Lid	16	35

* APPROX. LENGTH REQUIRED FOR MAINTENANCE.
DIMENSIONS ARE IN MM [INCH]

7. Technical Specifications SAF-X 4500

General

Maximum flow rate	240 m ³ /hr	1,060 gpm	Consult manufacturer for optimum flow depending on filtration degree & water quality.
Design Pressure	10 bar(g)	150 psi	
Min. Operating pressure	2.0 bar(g)	30 psi	Pressure is critical during the flushing cycle. Consult manufacturer for the required values according to filtration degree and operation conditions.
Temperature Min / Max	4 ^o / 50 ^o C	39.2 ^o / 122 ^o F	
Filtration area	4500 cm ²	700 in ²	
Inlet/Outlet diameter	100,150,200 mm	4", 6", 8"	Flange standards as per request.
Filter housing	250 mm	10"	Epoxy-coated steel, or other on request.
Weight: empty / Operation	100 mm = 137/226 Kg 150 mm = 142/231 Kg 200 mm = 151/240 Kg	4" = 301/497 lb. 6" = 312/508 lb. 8" = 332/528 lb.	

Flushing Data

Exhaust valve	50 mm	2"	
Flushing cycle time	20 seconds	20 seconds	
Reject volume per cycle	117 liter	30 gallon	STD Nozzle at 2.5 bar/35 psi
Minimum flow for flushing	21 m3/h	93 gpm	

Control and Electricity

Control voltage	120 & 24 VAC or 24VDC
Electric motor	1/4 HP (0.18 kW) 50/60 Hz,
Rated operation Voltage	3 phase 208/230/380/400/415/460/575 Volt 50/60 Hz Single phase, 120/240 Volt 50/60 Hz
Current consumption	0.6 Amp. (see electrical diagram for specific values)

Construction Materials

Filter Housing and Lid	Epoxy-coated carbon steel 37-2 (Stainless Steel 316 available on request).
Screens	Stainless Steel 316
Cleaning mechanism	Stainless Steel 316, POM, PVC
Exhaust valve	Epoxy-coated cast iron, Natural Rubber
Seals	Synthetic Rubber
Control	Aluminum, Brass, Stainless Steel, PVC

Standard Filtration Degrees

	Stainless Steel Weave-wire Screen											
micron	800	500	300	200	130	100	80	50	40	30	20	10
mm	0.8	0.5	0.3	0.2	0.13	0.1	0.08	0.05	0.04	0.0	0.02	0.01

8. GA Drawing – 6” SAF-X 4500 (available also with 4” and 8” connections)

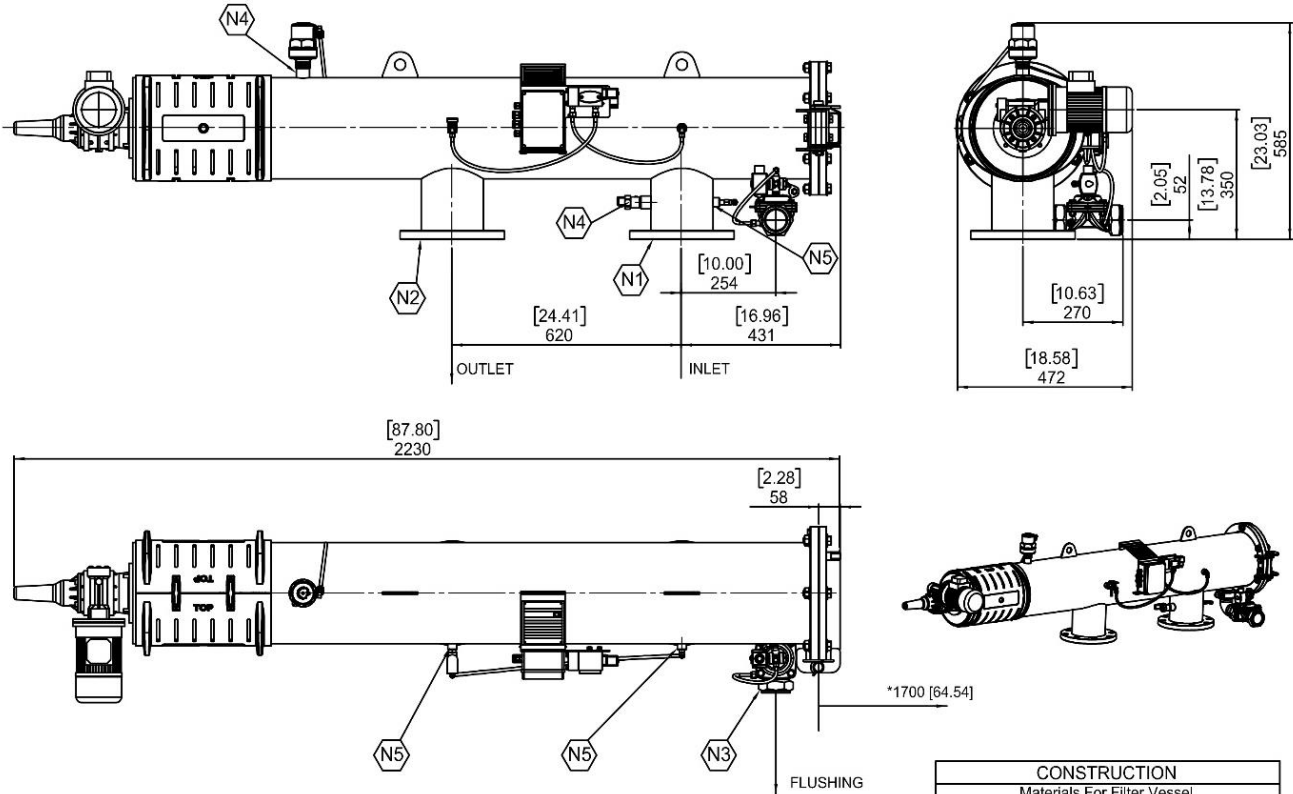

NOZZLES LIST						
CODE	QTY.	DN	CLASS	PIPE	FLANGE TYPE	SERVICE
N1	1	6"	BY DEMAND	VARY	S.O.R.F	INLET
N2	1	6"	BY DEMAND		S.O.R.F	OUTLET
N3	1	2"	BSP		Thread (F)	FLUSHING
N4	2	3/4"	BSP		Thread (F)	Drain / Air Release
N5	3	1/4"	BSP		Thread (F)	INSTRUMENTATION

* APPROX. LENGTH REQUIRED FOR MAINTENANCE.
DIMENSIONS ARE IN MM [INCH]

CONSTRUCTION		
Materials For Filter Vessel		
Housing / Lid: C/ST		
Flanges: See Class		
DESIGN CRITERIA		
Design Code	EN-13445	
Design Pressure	10 Bar [145 psi]	
Design Temperature	50°C [° F]	
Volume	89 L [23.5 gallon]	
TOTAL WEIGHT		
	KG	LB
Empty	142	313
Operating	229	504
Lid (without accessories)	11	24

9. Description of Filter Operation

Introduction:

The SAF-X Series is sophisticated yet easy-to-operate family of automatic filters, with a self-cleaning mechanism driven by an electric motor.

The SAF-X is designed to work with various types of screens in filtration degrees from 10 to 800 micron.

There are three models in the series, 4500, 3000 and 1500. Each model is available in three different inlet/outlet diameters.

Filtering process:

Feed water enters from the filter inlet, passes through the coarse screen from outside in, and through the fine screen from inside out. Filtered water flows through the filter outlet.

The gradual dirt buildup on the inner screens surface causes an increase of the pressure differential across the filter. The self-cleaning process begins when the pressure differential reached a pre-set value.

The coarse screen is designed to protect the cleaning mechanism from large objects.

Usually, it does not accumulate large quantities of suspended solids and therefore it is not cleaned automatically.

Self-cleaning process:

The SAF-X initiates the self-cleaning process when either the pressure differential across the fine screen reaches a pre-set value or the flush timer reaches its preset timed interval.

The exhaust valve opens, creating high velocity suction force at the scanner's nozzles' edges which "vacuums" the filter cake from the screen's surface.

A 2-way (fwd/rev) drive unit that is connected to the scanner by a threaded shaft rotates the scanner and provides the spiral path movement.

The exhaust valve is activated for the duration of the cleaning cycle by a 3-way solenoid. During the 20 seconds self-cleaning process, filtered water continues to flow downstream.

Cleaning Cycle Stages

- Exhaust valve opens to atmosphere.
- 3 seconds' delay.
- Motor starts rotating the suction scanner outward (CCW) until reach the outer limit switch (TLS).
- Motor stops and the exhaust valve closes.
- The filter is ready for the next flushing cycle.

In the next flush cycle, the motor will rotate the scanner inward (CW) until reach the inner limit switch (BLS).

Cross Section illustration

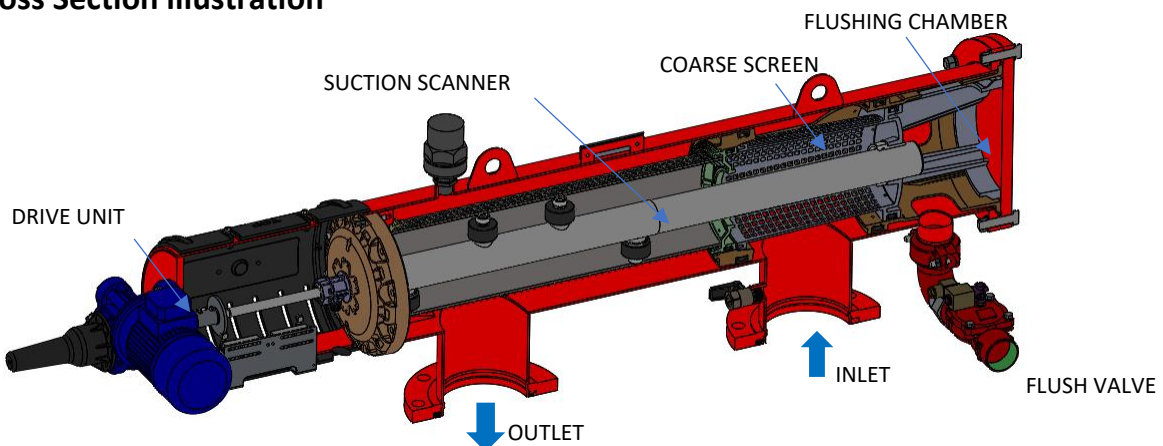

Operation Modes

The SAF-X may be found in any of the following modes:

1. **Filtering mode:** This is the normal function condition. DP value is below set point. Flushing is not active, and the control system is ready to initiate a flushing cycle.
2. **Flushing mode:** A mode in which the flushing process is in progress. The motor and the exhaust valve are operating according to the program.
3. **Continuous flushing mode:** Flushing process continue regardless DP. Flushing valve remains open. suction scanner moving back and forth with 2 seconds delay between strokes. Continuous flushing mode is used in heavy contamination loads conditions to prevent increasing of DP. Continuous mode should be used for limited time only in order to save water, energy, and mechanical wear.
4. **Malfunction mode:** During malfunction mode the self-cleaning operation is stopped, filtration may continue but DP is climbing up and flow will be reduced. A fault light on the control board should turn on and a relevant message should be displayed on the HMI.

The filter will enter a malfunction mode in the following cases:

- High DP for duration longer than a pre-set time. This means that the self-cleaning process is not successful.
- Motor protector tripped due to mechanical resistance or electrical failure.
- Limit Switch failure.

Initiation of Self-Cleaning

Flush Cycle may start as a result of any of the following:

1. Pressure Differential
2. Time Interval
3. Manual Start from local control panel.
4. Manual Start from remote control system.

Pressure Differential Operation

There are three options for DP measuring:

- a. Pressure Differential Switch (fixed or adjustable)
- b. Analog Differential Pressure Transmitter
- c. 2 X Pressure Transmitters, one connected to the filter inlet and one to the outlet.

A flush cycle starts if the PD Value (calculated or measured) is \geq Pre-Set value for at least 3 seconds. The signal for flushing will remain ON as long as the PD value \geq Pre-Set value + 5 seconds.

The Pre-Set PD value may be fixed (PDS) or may be defined through the HMI.

Time Interval

Cleaning according to a pre-set time interval is recommended as an option.

The Time Interval shall be determined through the HMI.

The flush cycle starts when the time counter is \geq to the pre-set time.

The time counter is re-set back to zero when any flush cycle begins (regardless of whether it is a result of PD, time or manual start).

Manual / Test Operation

Push-Button (Hardware or on the HMI) to start Flush cycle regardless DP or time interval.

Suction Nozzle types:

All SAF-X filters are available with both suction nozzle types:

SLN (Spring Loaded Nozzle) which is touching the inner support layer of the screen element to achieve maximum suction/cleaning forces.

The SLN is the default for fine filtration in the 10-to-50-micron range.

Non SLN which keeps a gap of about 2 mm between the nozzle's tip and the inner support layer of the screen element.

The NON SLN type is the default for filtration degrees of 80 micron and above.

10. Installation Instructions

General

1. Before beginning the installation process, carefully read the safety instructions section and make sure that all workers at the installation site are fully aware of and comply with, these and any other local safety instructions.
2. If possible, prior to installing the filter, thoroughly flush the main line at the connection point to remove large objects that may damage the filter's internal parts.

Design considerations:

1. Water supply system (pump or network) should be suitable to provide the working flow plus the required flushing flow rate as per manufacturer recommendations. (check the technical specification of the specific SAF-X model).
2. Valves and peripheral instrumentations:
 - a. Manual isolating upstream valve is required for maintenance and service activities.
 - b. Downstream valve (automatic or manual) is required to control the flow and ensure sufficient back-pressure for flushing.
Note: Various options for flow and pressure regulation are available. Consult manufacturer for optimal solution for the given conditions.
 - c. By-Pass valve - If continuous water flow is required, it is essential to have an automatic or manual by-pass valve.
 - d. Non-return valve downstream of the filter is required in any installation where there is a risk of static back pressure or reverse flow.
Note: Damage caused by back-pressure or reverse flow through the filter is not covered by the filter warranty, therefore non-return valve installation is highly recommended.
 - e. Pressure Gauge – It is highly recommended to have pressure indicators upstream and downstream of the filter.
3. Flush pipe arrangement:
 - a. Diameter of the flush line should be 2" minimum and should be designed to create minimal resistance with the flushing flow rate (Check the technical specifications for the relevant value).
 - b. If length of the flushing line is more than 5m (16 ft.), changing it to 3" is recommended.
 - c. Consult manufacturer for solutions in cases where the flushing line is going to a higher level.
 - d. In case operating pressure of the system is higher than 6 bar (85 psi), a throttling gate or ball valve is required to enable controlling the flushing flow rate.
A pressure gauge or at least a pressure check point should be located between the flush valve and the throttling valve to enable flow adjustment.
 - e. In case operating pressure of the system is higher than 10 bar (150 psi), special considerations are required, please consult the manufacturer for proper design and arrangement of the flushing line.
4. Multiple Systems (Two or more filter units mounted on a common manifold):
 - a. Inlet and outlet manifolds should be over-sized to enable even distribution of the flow.
 - b. One Pressure differential measuring between the inlet and outlet manifolds is required to initiate sequential operation of the filtration battery. Sensors may be mounted on one of the filtration units, but the sensing ports should be on the main manifolds.
 - c. Install isolation valves at the inlet and outlet of each unit for easy maintenance.
 - d. Install common throttling/flow control valve downstream of the system to enable flow and pressure regulation.
 - e. Flushing manifold should be designed to handle the flushing flow rate of at least two filter units flushing simultaneously.

Mechanical installation

1. Install the filter on a stable piping system taking in consideration that the filter is supported by its inlet and outlet pipe connections.
2. In case of installation on PVC or other polymeric piping, it is recommended to use additional metallic support brackets to ensure stable installation.
3. Leave enough space to enable access for inspection and maintenance. Check the GA drawing for the correct measurements.
4. Arrange suitable lighting at the area of the filter to enable good visibility and safe maintenance.
5. Tighten the filter flange to piping flange as follows:
 - If there are bolts and nuts - hold the bolt and tighten the nut where possible.
 - Do not use power tools which are not torque adjustable.
 - Use electric or pneumatic tools adjusted to minimum torque and make final tightening by torque wrench.
 - Both initial threading and final tightening to be done in criss- cross sequence as shown in the figures below.

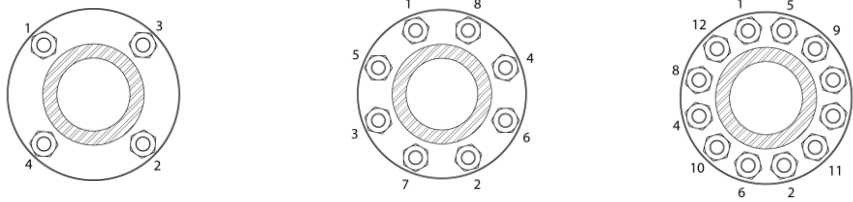

Electrical installation

All electrical works at the installation site must be done by a qualified and authorized electrician.

Make sure that this electrician is fully aware of all the relevant safety instructions, is familiar with the electrical design of the system and has in hand the relevant approved wiring diagrams.

Make sure to review and follow the relevant safety instructions on [page 4](#) of this document.

1. **Control Panel** – Amiad Control panels are suitable for outdoor installation; however, dry, and protected place is always preferred. Eye contact between the control panel and the filter is highly recommended.
2. **Motor wiring** – Use long enough cable to allow the drive unit to be removed and placed near the filter for maintenance, without having to disconnect them from the cable.
3. **Cable recommendation:**
 - 4G2.5 mm² /14 AWG (according to installation & MCB protection)
 - Suitable for outdoor applications, UV, Weather, Flame and Oil retardant.
 - Flexible – (each core is made of fine wire strand made of bare copper wires).
 - Color coded or core number coded.
 - Nominal voltage 500V.
 - Temperature range -15°C to +70°C. / 5°F to 158°F
4. **Power supply wiring** – Follow local regulations for size and Short Circuit Current Ratings (SCCR) requirements. It is the responsibility of the installer to insure this is done correctly.
5. **Control wiring** - Connect the terminals between the junction box and the control panel using 6 x 1.5 mm² (16 AWG) wires in flex-conduit. Usually, the numbers on the terminals in the board correspond with those in the junction box. However, double check before starting.

Pneumatic installation (if applicable)

The pneumatic connection refers only to the actuator of the flushing valve.

Review the data sheets of the solenoid and verify the connection type for the air supply (type & dimensions)

Air supply should be pressure regulated, dried, and featured with a pressure release mechanism.

Typical Installation Drawing

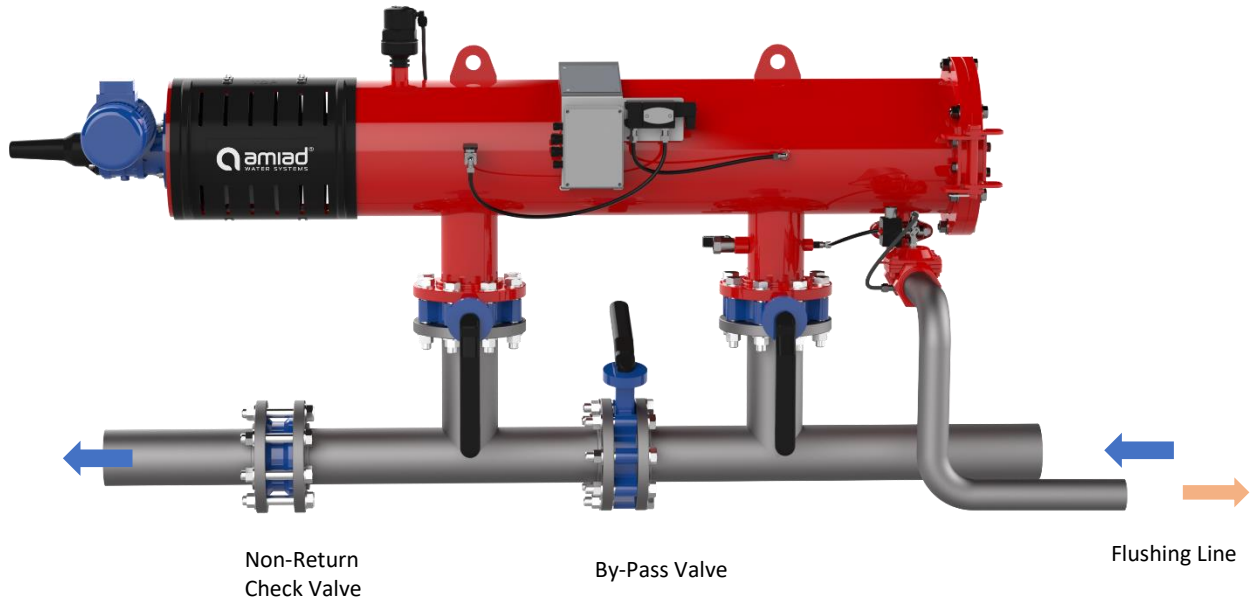

Start-up and first operation

1. Make sure all the electrical cables are properly wired according to the relevant drawings.
2. Turn on control power and 24VAC but leave OL protector off. Verify that the limit switches are wired correctly by manually toggling them. Monitor the appropriate inputs according to the wiring diagram accompanying the control panel. Proceed to next step only after verifying correct wiring of all limit switches in the system.
3. CHECK ROTATION: The suction scanner shaft should turn clockwise (CW) and move towards the filter housing until it reaches the inner limit switch (BLS). If the motor rotates in the opposite direction (CCW), turn off the power immediately and change the direction of the motor rotation by changing the phase order. (By authorized electrician).
4. The motor must stop when the limit switch plate reaches the limit switch (opening the NC circuit).
5. Operate a "dry" flushing cycle by pressing on the "TEST" push button. Check that the flushing cycle runs as described in the "Self-cleaning process" paragraph in this manual.
6. Open the inlet valve to the filter, leaving the outlet valve closed or with an open by-pass valve (This will keep the flow through the filter to a minimum), and initiate a flush cycle.
7. Check that the exhaust valve opens, and all stages of the flushing cycle perform properly. Attend to leakage, if any.
8. Close the 1/4" valve at the low-pressure sensing port and drain the low-pressure side of the PDS. The instrument should switch ON and after 5 seconds, flush cycle should start. Re-open the 1/4" valve.
9. Gradually open the outlet valve and/or close the by-pass valve. Operate the filter under the designed hydraulic conditions.
10. Set the flushing interval timer for 6-8 hours.
11. Check and re-tighten all bolts after the first week of operation.

11. Commissioning

Pre-Commissioning

Step	Action	Comments	Confirm
1.	Verify that all piping is connected and tightened		
2.	Verify that inlet, outlet and drain valves are closed		
3.	Verify that power and control wiring are completed.	Power available but main switch is disconnected.	
4.	Verify that Flushing Valve Solenoid or Actuator is properly wired.		
5.	If applicable - operate the flush valve manually and verify that it is Normally Closed.		
6.	Verify that the scanner is positioned in the middle of its travel. If not, remove the Drive Unit and turn the shaft manually, so no limit switch will be activated.		
7.	Turn ON the control Power. Power for the motor should be on "Manual" at this stage.	It is possible to run the motor manually, but it will not run automatically.	
8.	Operate momentarily the motor Outward (upward) and verify that scanner is indeed moving Out (CCW)	Switch rotation direction of the motor if required.	
9.	Operate momentarily the motor Inward (downward) and verify that scanner is indeed moving in (CW)	Switch rotation direction of the motor if required.	
10.	Verify that both Limit Switch inputs are in ON state (Switches are NC, so PLC inputs should be ON)	Make sure to have eye contact between the motor and the operator so motor can be stopped manually in case the PLC program is not working.	
11.	Turn on the motor inward and verify it stops by BLS.		
12.	Turn on the motor outward and verify it stops by TLS.		
13.	Initiate "dry" Flush Cycle from local Control panel or from HMI and follow the sequence. Verify activation of the solenoid or opening and closing of the flush valve.	For details, refer to the Control System Section.	

Commissioning

Step	Action	Comments	Confirm
1.	Slightly open the Inlet valve and fill the filter gradually until no more air is coming out from the air release valve.		
2.	Open the inlet valve completely		
3.	Verify that the pressure in the filter is within the designed working pressure of the filter	Inspect and remedy any leaking.	
4.	Initiate manual full flush cycle	Verify opening of the flush valve. Check and eliminate any leaking.	
5.	Turn the system into continuous flushing mode and start to open the outlet valve.	Watch the DP across the filter and make sure DP value not exceed 0.3 bar (4 psi). In case DP is higher, slightly close the downstream valve to reduce the flow.	
6.	Bring the system to its designed working flow rate		
7.	Switch off the continuous flushing mode and turn it to work according to DP with time backup of 6 hours.		
8.	Simulate HDP and HHDP conditions and verify the reaction of the control system	For details, refer to the Control System Section.	
9.	Follow and study the system functioning for fine tuning of the flushing interval, and DP set points.		

Note:

Not all control features are available in all control panels types and models.

For details, refer to the specific manual given with the relevant control panel.

A detailed Control Philosophy document is available for cases that the PLC is programmed by others.

Shutoff Procedure

1. Prior to system shutoff it is highly recommended to initiate manual flush cycle.
2. ALWAYS, close outlet valve before closing the inlet valve.
3. Release the pressure by opening the drain valve.
4. Consult manufacturer for storage recommendation according to the application, type of water and environmental conditions.
5. Make sure to drain the filter completely, including all instrumentation tubes if there is any risk of freezing during the storage period.

12. Part Schedule

SAF-X 1500 / 3000 / 4500

ITEM NO.	CAT. NO.	DESCRIPTION	QTY.	MATERIALS
1		SAF-X-HOUSING (CHECK MODEL, SIZE & FLANGE STD)	1	POLYESTER COATED C/S
2	710105-005905	SAF-X FRONT LID	1	POLYESTER COATED C/S
3	710105-005906	SAF-X HINGE PLATE	2	POLYESTER COATED C/S
4	760111-000004	SAF-X FRONT FLANGE HANDLE	1	PA
5	710103-011309	SAF-X FRONT FLANGE HINGE PIN	1	S/ST 304
6	760105-000009	PIN COTTER 4 X 40 MM DIN 94	1	S/ST 316
7	710101-001625	SAF-X SEALING SLEEVE	1	PP+GF
8	710101-001607	SAF-X COARSE SCREEN	1	PP+GF
9	710103-002117	FLUSH CHAMBER SCANNER BEARING	1	POM
10		SAF-X WW SCREEN (SEE TABLE ON PAGE 20)	1	S/ST 316 + VARIOUS
11		STD SCANNER ASSEMBLY (SEE TABLE ON PAGE 21)	1	S/ST 316 + VARIOUS
18		SLN SCANNER ASSEMBLY (SEE TABLE ON PAGE 22)	1	S/ST 316 + VARIOUS
25	710103-011692	SAF-X REAR-SIDE FLANGE	1	PA6+GF
26	700190-006190	SAF-X SHAFT SEALING ASSEMBLY	1	VARIOUS
27	710103-011299	SAF-X SHAFT SEALING STOPPER	1	S/ST 304
28	710103-011298	SAF-X BACK FLANGE SHAPED WASHER	10	S/ST 304
29	710101-001609	SAF-X SIDE COVER	2	PP
30	710103-011329	SAF-X BRACKET FOR LIMIT SWITCH	1	S/ST 304
31	710103-002233	DRIVE BUSHING	1	PHOSPHOR BRONZE
32	710103-011314	SAF-X DRIVE SHAFT	1	S/ST 303
33	710103-002237	DRIVE SHAFT KEY	1	BRASS
34	710103-011328	SAF-X PLATE FOR LIMIT SWITCH	1	S/ST 304
35	710103-011313	SAF-X SHAFT ADAPTOR	1	S/ST 303
36	760105-000097	CLEVIS PIN 3/16" X 1-1/16"	2	Z. PLATED C/ST
37	760105-000052	PIN COTTER 3/64 X 5/8 MM	2	S/ST 316
38	760106-000010	EXTERNAL RETAINING RING 25 MM DIN 471	1	S/ST 316
39	710101-001613	DRIVE SHAFT COVER	1	PP
40	780102-000020	2" VICTAULIC CONNECTOR	1	C/ST
41	780101-001671	2" GROOVED ELBOW	1	DUCTILE IRON
42	780101-000822	2" GALVANIZED M CONNECTOR	1	GALVANIZED CS
100	770102-000176	O-RING 2-452 70 SHORE	1	NBR
101	770104-000403	SAF-X SEALING SLEEVE HYDRAULIC SEAL	2	EPDM
102	770104-000404	SAF-X COARSE SCREEN HYDRAULIC SEAL	1	EPDM
103	770101-000040	O-RING 60 X 4 70 SHORE	1	NBR
104	770104-000400	SAF-X SCREEN HYDRAULIC SEAL	2	EPDM
105	770102-000161	O-RING P 2-370 70 SHORE	1	NBR
106	770102-000093	O-RING P 2-126 70 SHORE	1	NBR
109	770104-000027	GASKET FOR 2" VICTAULIC CONNECTOR	1	EPDM
200	760101-000329	HEX BOLT PARTIAL THR M16 X 65	6	Z. PLATED C/ST
201	760103-000069	FLAT WASHER M16 DIN125	12	Z. PLATED C/ST
202	760102-000067	HEX NUT M16 C/ST DIN934	6	Z. PLATED C/ST
203	760103-000100	FLAT WASHER M16 DIN125	2	S/ST 304L
204	760103-000229	FLAT WASHER M16 DIN125	2	PA
205	760101-000798	M12 20MM DIN933	4	S/ST 316
206	760103-000098	FLAT WASHER M12 DIN125	4	S/ST 304
207	760101-000696	SOCKET HEAD CAP SCREW M6 15MM DIN912	2	S/ST 316
208	760101-000703	SOCKET SET SCREW M10 X 60 DIN916	10	S/ST 316
209	760102-000087	HEX NUT M10 DIN934	10	S/ST 316
210	760101-001552	PHILLIPS PAN TAPPING SCREW NO.10 1/2"	2	S/ST 304
211	760101-000308	HEX BOLT FULL THRD M8X40	4	Z. PLATED C/ST
212	760103-000075	FLAT WASHER M8 DIN125	8	Z. PLATED C/ST
213	760103-000085	SPRING WASHER M8 DIN127	4	Z. PLATED C/ST
214	760102-000063	HEX NUT M8 DIN934	4	Z. PLATED C/ST
215	760101-001208	SOCKET HEAD CAP SCREW M8 16MM DIN912	4	S/ST 316

ITEM NO.	CAT. NO.	DESCRIPTION	QTY.	MATERIALS
216	760101-000511	PHIL PAN MACHIN M4 20MM DIN7985	4	S/ST 304
217	760103-000092	FLAT WASHER M4 DIN125	4	S/ST 304
218	760102-000099	NYLON INSERT LOCKNUT M4 DIN985	4	S/ST 304
219	760101-000444	HEX BOLT FULL THRD M6 20MM DIN933	2	S/ST 304
220	760103-000109	SPRING WASHER M6 DIN127	2	S/ST 316
221	760101-001553	HEX BOLT FULL THRD M6 30MM	4	Z. PLATED C/ST
223	760101-000545	SOCKET SET SCREW M6X25 DIN916	2	S/ST 304
224	760101-000447	HEX BLT FUL TH M6 35MM S/ST304 DIN933	3	S/ST 304
225	760103-000094	FLAT WASHER M6 DIN125 S/ST316	3	S/ST 316
226	760102-000101	NYLON INSERT LOCKNUT M6 S/ST304 DIN985	3	S/ST 304
300	730103-000467	FLUSHING VALVE - 2" DOROT GAL 44 BSP (*)	1	CAST IRON
301	720103-000182	SOLENOID VALVE 24VAC NO ASCO RED HAT (*)	1	VARIOUS
302	710103-000591	NIPPLE 1/4" BSPT PRESSURE CHECK	1	BRASS
303	720501-000206	CONNECTOR 5/16" X1/4"	1	BRASS
304	720501-000202	L-CONNECTOR 1/4"M X5/16" BSPT	5	BRASS
305	730110-000034	1/4"M/F FINGER FILTER PLASTIC BLACK	1	VARIOUS
306	730104-000232	2-WAY BALL VALVE 3/4" M/F	1	NICKEL PLATED BRASS
307	720502-000036	CONTROL TUBE 5/16" BLACK	6	PA
308	720501-000213	CONNECTOR 5/16"X1/8" 68F	2	BRASS
309	730108-000113	AIR RELEASE VALVE D-040-P 3/4" BSPT	1	PP
310	700190-002336	MANOMETER VALVE 1/4" W/ DRAIN ASSY	1	VARIOUS
311	720202-000019	GEAR RMI50 63 B5 1/28 SITI MT-5010	1	VARIOUS
312	720203-000033	MOTOR SITI/STM 380/480V AC 3P .18KW	1	
313	700190-002618	PD SWITCH MIDWEST ASSEMBLY (*)	1	VARIOUS
314	700190-002421	ELECTRIC JUNCTION BOX	1	VARIOUS
315	720302-000004	LIMIT SWITCH FA 4131-2DN NC	2	VARIOUS

(*) various types are used in different markets and applications. Please verify the type you need.

Screen Elements for SAF-X 1500 / 3000 / 4500

When ordering, please indicate your specific screen element characteristics:

Model: SAF-X 1500, SAF-X 3000 or SAF-X 4500

Filtration Degree: 10; 20; 30; 40; 50; 80; 100; 130; 200; 300; 500; 800 micron

ITEM NO.	CAT. NO.	DESCRIPTION	QTY.	MATERIALS
10	700101-002XXX	WEAWEWIRE SCREEN FOR SAF-X 1500 XXX MIC. WITH SEALS	1	S/ST 316
10	700101-002XXX	WEAWEWIRE SCREEN FOR SAF-X 3000 XXX MIC. WITH SEALS	1	S/ST 316
10	700101-002XXX	WEAWEWIRE SCREEN FOR SAF-X 4500 XXX MIC. WITH SEALS	1	S/ST 316

Suction Scanners:

Two types of scanners are available:

STD (Non SLN) Suction Scanner, used for 80-to-800-micron applications (Item #11).

SLN Suction Scanner, used for fine filtration 50 micron and below (Item #18).

STD (Non SLN) Suction Scanners parts schedule:

SAF-X 1500

ITEM NO.	CAT. NO.	DESCRIPTION	QTY.	MATERIALS
11	700190-006223	SCANNER ASSEMBLY FOR SAF-X 1500 – INJECTED NOZZLES	1	VARIOUS
12	710103-011319	SUCTION SCANNER SHAFT SAF-X	1	S/ST 316
13	760105-000098	DOWEL PIN 6X36 DIN7	1	S/ST 316
14	710103-002501	PLUG 8MM SAF FOR SCANNER	1	POM
15	710102-004616	SAF-X-1500 SUCTION SCANNER S/ST316 NON SLN	1	S/ST 316
16+17	710101-000922	MOLDED SCANNER NOZZLE - PART 1 & 2	2	PP+GF
222	760101-000537	PHILLIPS PAN TAP SCREW PT4X20	8	S/ST 316

SAF-X 3000

ITEM NO.	CAT. NO.	DESCRIPTION	QTY.	MATERIALS
11	700190-006224	SCANNER ASSEMBLY FOR SAF-X 3000 – INJECTED NOZZLES	1	VARIOUS
12	710103-011319	SUCTION SCANNER SHAFT SAF-X	1	S/ST 316
13	760105-000098	DOWEL PIN 6X36 DIN7	1	S/ST 316
14	710103-002501	PLUG 8MM SAF FOR SCANNER	1	POM
15	710102-004617	SAF-X-3000 SUCTION SCANNER S/ST316 NON SLN	1	S/ST 316
16+17	710101-000922	MOLDED SCANNER NOZZLE - PART 1 & 2	4	PP+GF
222	760101-000537	PHILLIPS PAN TAP SCREW PT4X20	16	S/ST 316

SAF-X 4500

ITEM NO.	CAT. NO.	DESCRIPTION	QTY.	MATERIALS
11	700190-006201	SCANNER ASSEMBLY FOR SAF-X 4500 – INJECTED NOZZLES	1	VARIOUS
12	710103-011319	SUCTION SCANNER SHAFT SAF-X	1	S/ST 316
13	760105-000098	DOWEL PIN 6X36 DIN7	1	S/ST 316
14	710103-002501	PLUG 8MM SAF FOR SCANNER	1	POM
15	710102-004605	SAF-X-3000 SUCTION SCANNER S/ST316 NON SLN	1	S/ST 316
16+17	710101-000922	MOLDED SCANNER NOZZLE - PART 1 & 2	6	PP+GF
222	760101-000537	PHILLIPS PAN TAP SCREW PT4X20	24	S/ST 316

SLN Suction Scanners parts schedule:

SAF-X 1500

ITEM NO.	CAT. NO.	DESCRIPTION	QTY.	MATERIALS
18	700190-006222	SAF-X 1500 SLN SCANNER	1	VARIOUS
19	710102-004615	SAF-X-1500 SUCTION SCANNER SLN	1	S/ST 316
12	710103-011319	SUCTION SCANNER SHAFT SAF-X	1	S/ST 316
13	760105-000098	DOWEL PIN 6X36 DIN7	1	S/ST 316
14	710103-002501	PLUG 8MM SAF FOR SCANNER	1	POM
20	710103-002103	SLN SPRING SEAT	2	POM
21	760107-000049	SLN SPRING	2	S/ST 302
22	710103-002106	SLN HOUSING FOR SAF	2	S/ST 316
23	710103-002105	TIGHTENING NUT FOR SAF SLN	2	POM
24	710103-002104	SLN CAP FOR SAF	2	HMPE
107	710101-001281	SLN SEAL 16MM TPU	4	POLYURETHANE
108	770102-000064	O-RING P2-016 70 SHORE	2	NBR

SAF-X 3000

ITEM NO.	CAT. NO.	DESCRIPTION	QTY.	MATERIALS
18	700190-006221	SAF-X 3000 SLN SCANNER	1	VARIOUS
19	710102-004614	SAF-X-3000 SUCTION SCANNER SLN	1	S/ST 316
12	710103-011319	SUCTION SCANNER SHAFT SAF-X	1	S/ST 316
13	760105-000098	DOWEL PIN 6X36 DIN7	1	S/ST 316
14	710103-002501	PLUG 8MM SAF FOR SCANNER	1	POM
20	710103-002103	SLN SPRING SEAT	4	POM
21	760107-000049	SLN SPRING	4	S/ST 302
22	710103-002106	SLN HOUSING FOR SAF	4	S/ST 316
23	710103-002105	TIGHTENING NUT FOR SAF SLN	4	POM
24	710103-002104	SLN CAP FOR SAF	4	HMPE
107	710101-001281	SLN SEAL 16MM TPU	8	POLYURETHANE
108	770102-000064	O-RING P2-016 70 SHORE	4	NBR

SAF-X 4500

ITEM NO.	CAT. NO.	DESCRIPTION	QTY.	MATERIALS
18	700190-006206	SAF-X 4500 SLN SCANNER	1	VARIOUS
19	710102-004610	SAF-X-4500 SUCTION SCANNER SLN	1	S/ST 316
12	710103-011319	SUCTION SCANNER SHAFT SAF-X	1	S/ST 316
13	760105-000098	DOWEL PIN 6X36 DIN7	1	S/ST 316
14	710103-002501	PLUG NM SAF FOR SCANNER	1	POM
20	710103-002103	SLN SPRING SEAT	6	POM
21	760107-000049	SLN SPRING	6	S/ST 302
22	710103-002106	SLN HOUSING FOR SAF	6	S/ST 316
23	710103-002105	TIGHTENING NUT FOR SAF SLN	6	POM
24	710103-002104	SLN CAP FOR SAF	6	HMPE
107	710101-001281	SLN SEAL 16MM TPU	12	POLYURETHANE
108	770102-000064	O-RING P2-016 70 SHORE	6	NBR

13. Spare parts Kits

SAF-X STD Seals set 700194-000066 (applicable for all models)

ITEM NO.	CAT. NO.	DESCRIPTION	QTY.	MATERIALS
100	770102-000176	O-RING 2-452 70 SHORE	1	NBR
101	770104-000403	SAF-X SEALING SLEEVE HYDRAULIC SEAL	2	EPDM
102	770104-000404	SAF-X COARSE SCREEN HYDRAULIC SEAL	1	EPDM
103	770101-000040	O-RING 60 X 4 70 SHORE	1	NBR
104	770104-000400	SAF-X SCREEN HYDRAULIC SEAL	2	EPDM
105	770102-000161	O-RING P 2-370 70 SHORE	1	NBR
106	770102-000093	O-RING P 2-126 70 SHORE	1	NBR

Spare parts Kits for annual maintenance

CAT. NO.	DESCRIPTION
700194-000050	SAF-X 1500 SLN SCANNER PREVENTIVE MAINTENANCE ONE YEAR
700194-000051	SAF-X 3000 SLN SCANNER PREVENTIVE MAINTENANCE ONE YEAR
700194-000052	SAF-X 4500 SLN SCANNER PREVENTIVE MAINTENANCE ONE YEAR
700194-000053	SAF-X 1500 STD SCANNER NOZZLES PREVENTIVE MAINTENANCE ONE YEAR
700194-000054	SAF-X 3000 STD SCANNER NOZZLES PREVENTIVE MAINTENANCE ONE YEAR
700194-000055	SAF-X 4500 STD SCANNER NOZZLES PREVENTIVE MAINTENANCE ONE YEAR

Each Kit contains the following items:

SLN SCANNER PREVENTIVE MAINTENANCE ONE YEAR			QTY. PER SAF-X MODEL		
ITEM NO.	CAT. NO.	DESCRIPTION	1500	3000	4500
26	700190-006190	SAF SHAFT SEALING ASSEMBLY	1	1	1
24+108	700190-002400	SLN CAP ASSEMBLY (+O-RING)	2	4	6
107	710101-001281	SLN SEAL 16 MM TPU	4	8	12
36	760105-000097	CLEVIS PIN 3/16" X 1-1/16"	2	2	2
37	760105-000052	PIN COTTER 3/64 X 5/8 MM	2	2	2
ML-2	760190-000127	TUBE OF GREASE PG-21	1	1	1
ML-3	760190-000097	SPANJAARD NON-MELTING GREASE 100 GM TUBE	1	1	1

STD SCANNER NOZZLES PREVENTIVE MAINTENANCE ONE YEAR			QTY. PER SAF-X MODEL		
ITEM NO.	CAT. NO.	DESCRIPTION	1500	3000	4500
26	700190-006190	SAF SHAFT SEALING ASSEMBLY	1	1	1
16+17	710101-000922	MOLDED SCANNER NOZZLE - PART 1 + 2	2	4	6
222	760101-000537	PHILLIPS PAN TAP SCREW PT4X20	8	16	24
36	760105-000097	CLEVIS PIN 3/16" X 1-1/16"	2	2	2
37	760105-000052	PIN COTTER 3/64 X 5/8 MM	2	2	2
ML-2	760190-000127	TUBE OF GREASE PG-21	1	1	1
ML-3	760190-000097	SPANJAARD NON-MELTING GREASE 100 GM TUBE	1	1	1

14. Parts Drawings

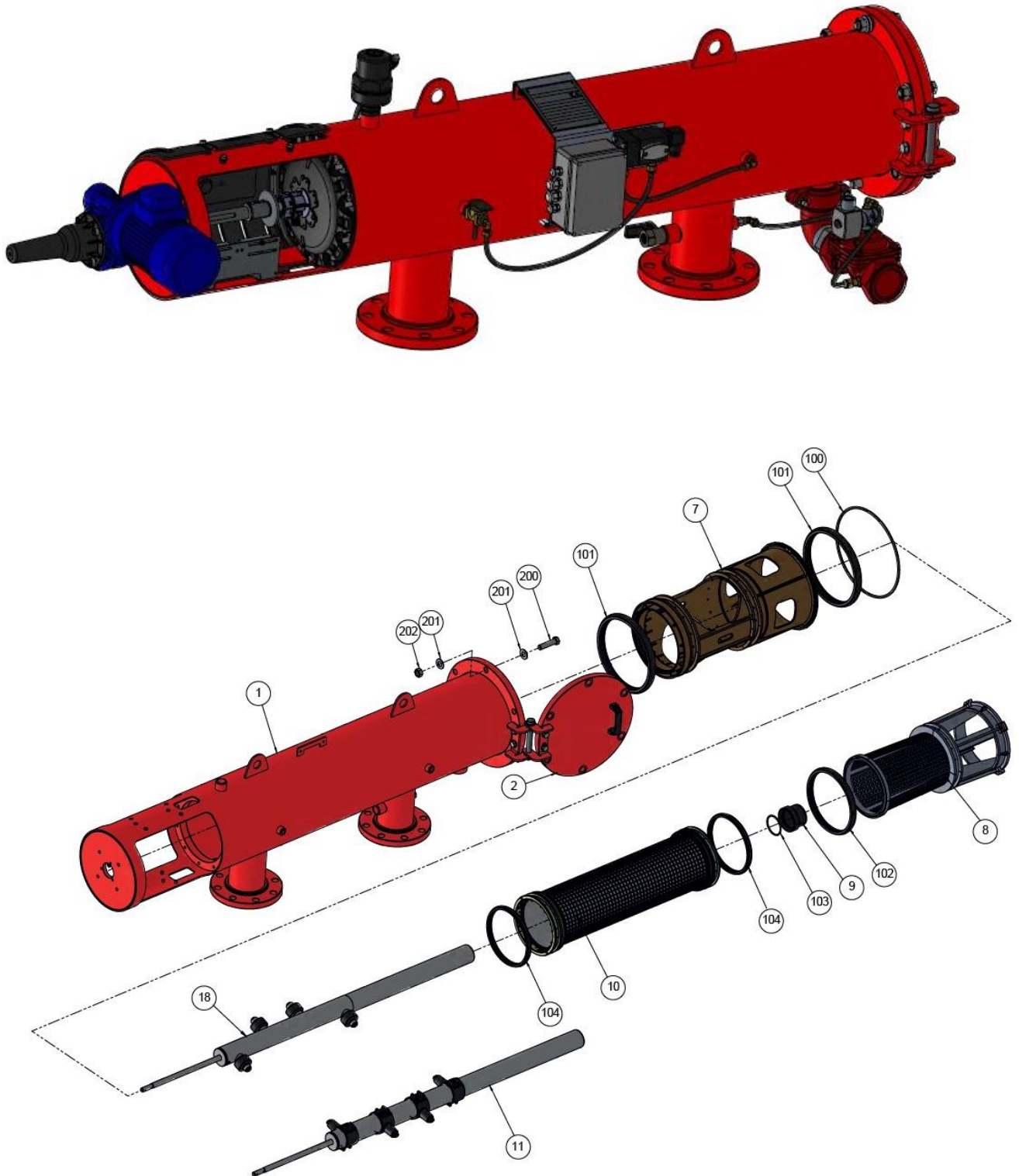

Item #18:
SLN Suction Scanner, used for fine filtration 50 and below.

Item #11:
STD (Non SLN) Suction Scanner, used for 80-to-800-micron applications.
(Check which one is relevant for your case).

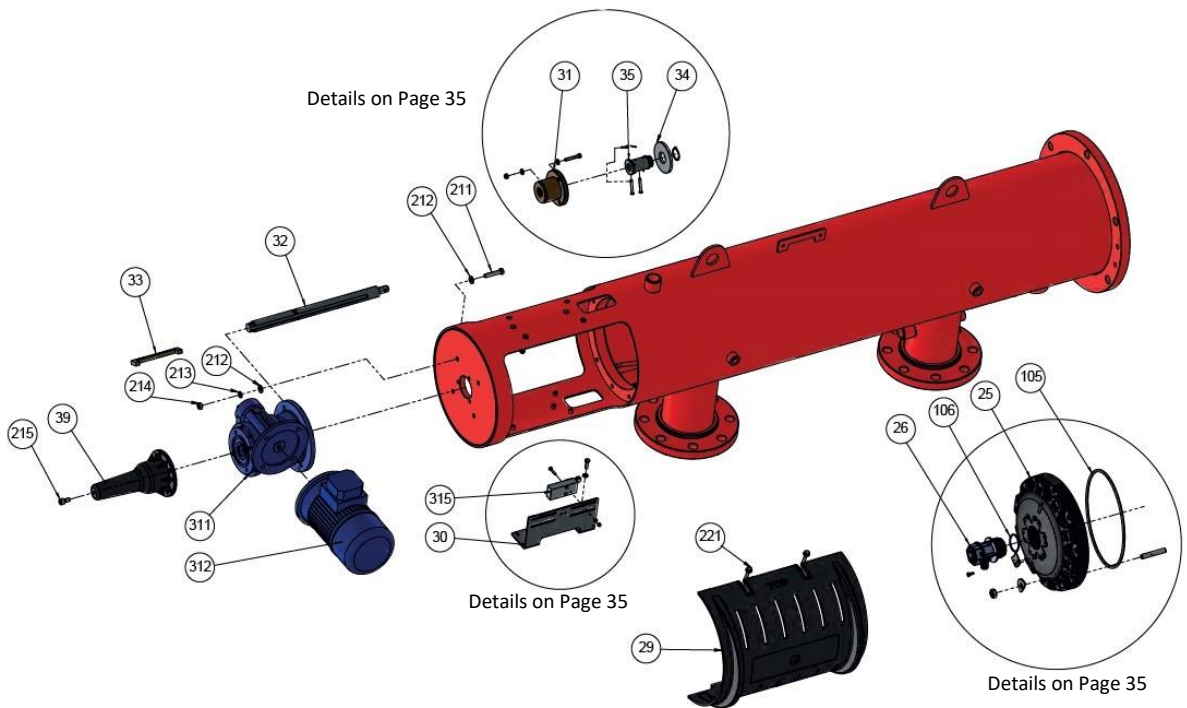
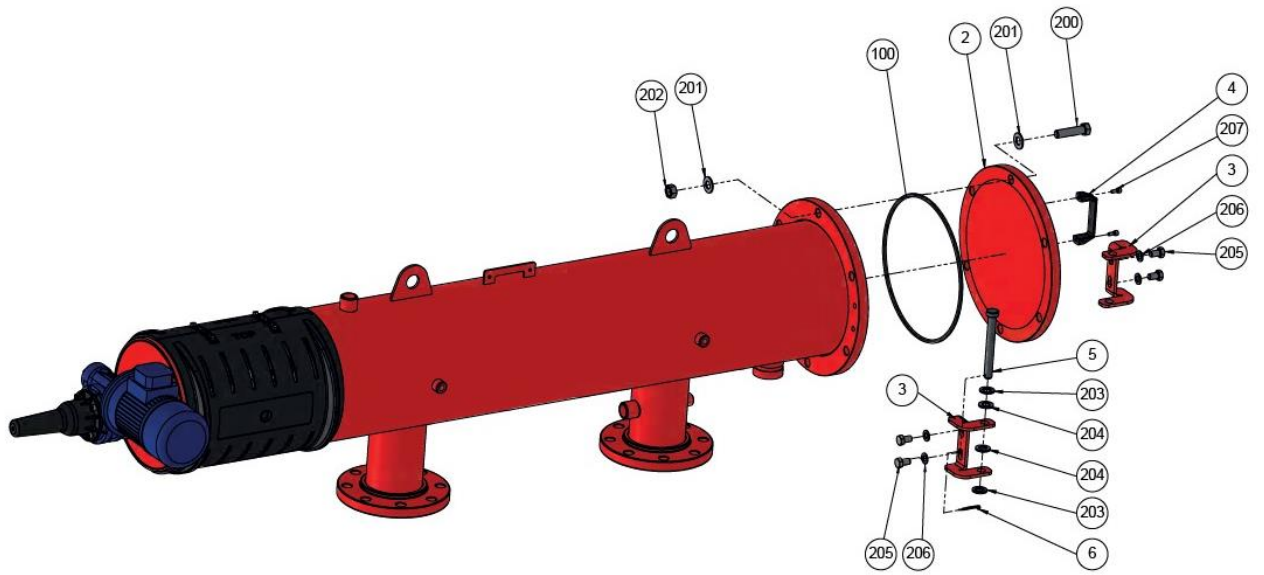

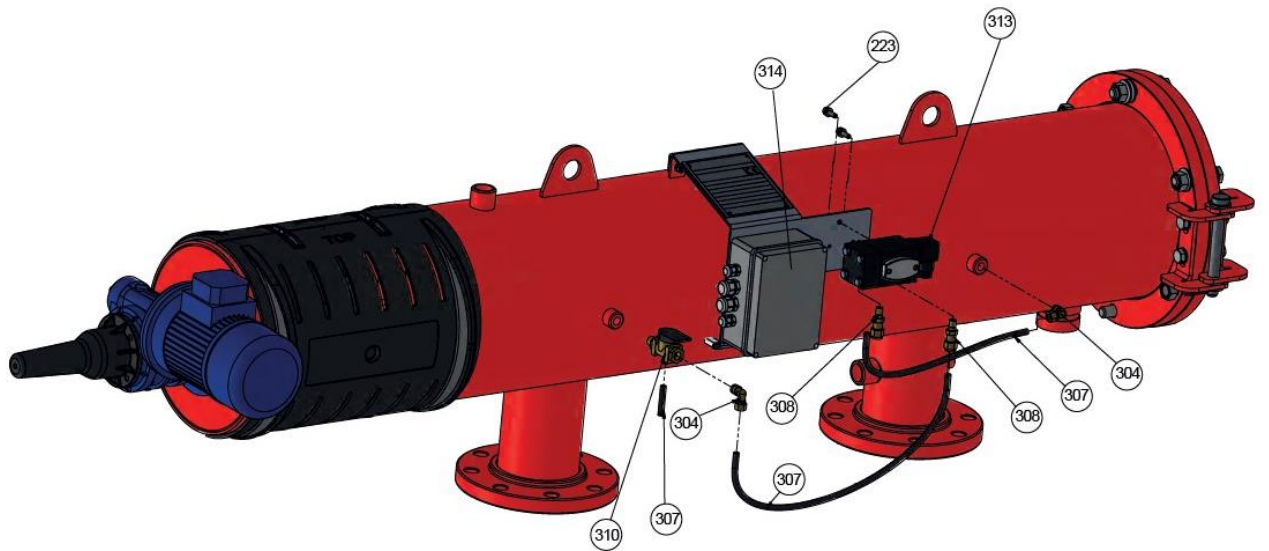
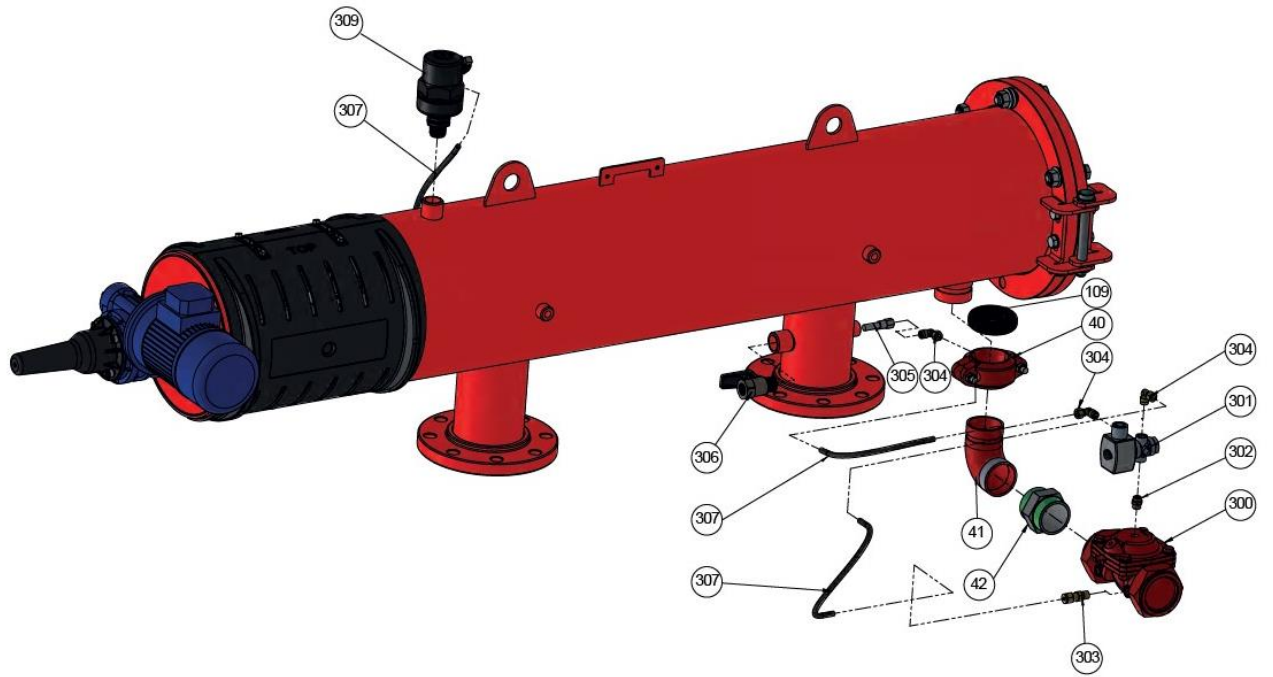

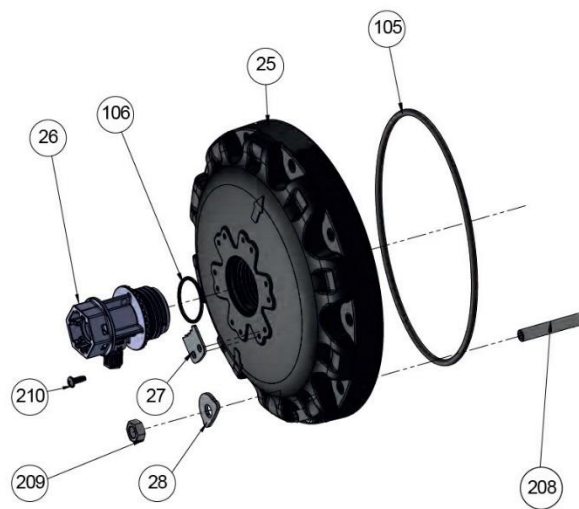
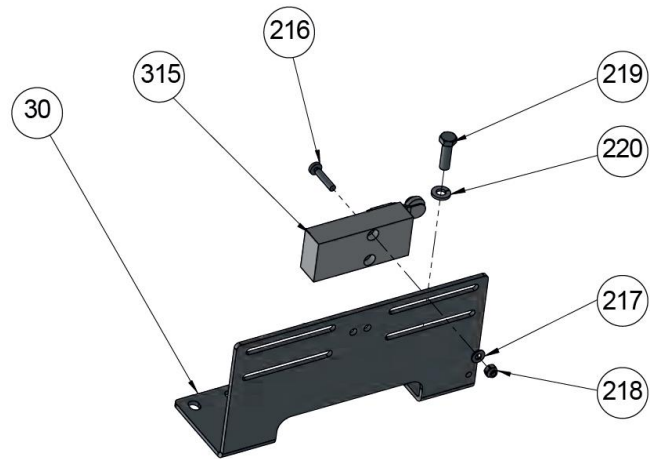
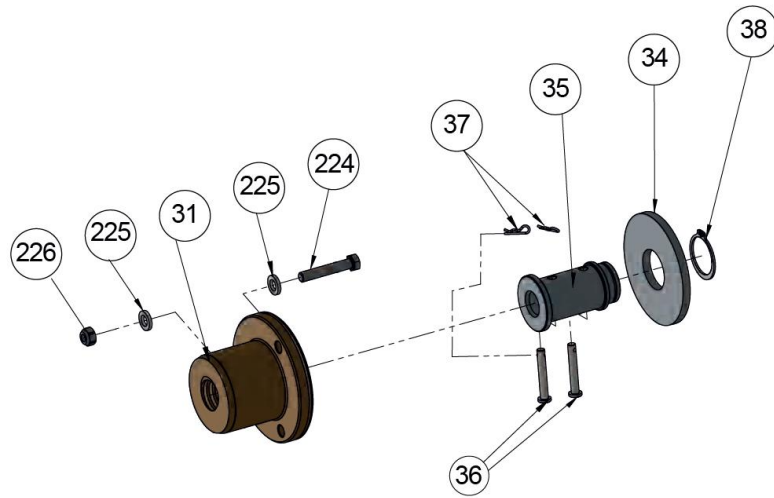

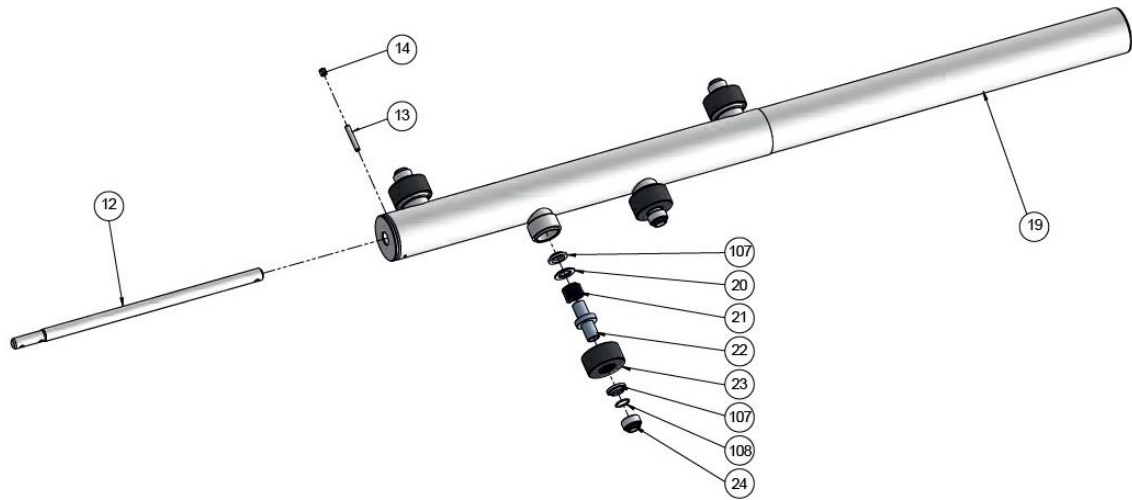

Item #18:
SLN Suction Scanner, used for fine filtration 50 micron and below.

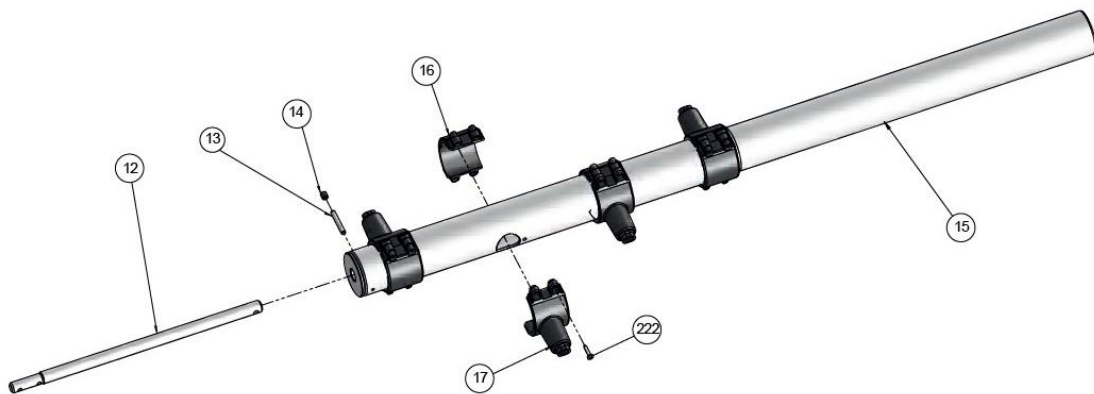



Item #11:
STD (Non SLN) Suction Scanner, used for 80-to-800-micron applications.







15. Maintenance

Equipment and Materials

Auxiliary materials (Materials will appear in the document by their ID)

.ID	Material Description	Figure
ML-1	<p>Thread locking Loctite 243 Used to lock bolts to avoid openings due to vibration. Cat. No. 780201-000031</p>	
ML-2	<p>Silicone Grease MOLYKOTE(R) PG-21 PLASTISLIP GREASE Used for O-ring lubrication Cat. No. 760190-000127</p>	
ML-3	<p>NON-MELT GREASE for lubrication of drive-shaft and motor key Cat. No. 760190-000097</p>	
ML-4	<p>Silicone Spray H1 for lubrication of seals and gaskets Cat. No. 780202-000012</p>	
ML-5	<p>Anti-Seize Grease WEICON ASW 450 prevent seizing of stainless-steel bolts and nuts Cat. No. 780202-000015</p>	

Tools and Equipment will appear in the document by their ID.

ID	Tool / Jig Description	Figure
TL-1	Seal Extractor	
TL-2	Hex Key (Allen): Standard metric set	
TL-3	Hex Sockets (1/2" drive): Standard metric set up to 24mm ○ 1/2" Drive Breaker Bar ○ 1/2" Drive Ratchet ○	
TL-10	Combination Wrench: Standard metric set up to 24mm	
TL-11	Flat Screwdriver: 6mm wide Philips Screwdriver #2	
TL-12	Long Nose Plier	
TL-13	Pin Punch: 3mm, 5mm, 6mm, 8mm	

Maintenance Policy

The maintenance requirements of automatic Self-Cleaning Filters are directly related to their Flushing frequency. Flushing frequency depends on flow rate and water quality (Suspended Solids type, load, and Chemistry). Therefore, the frequency of scheduled routine maintenance activities should be determined during the commissioning and first few months of operation.

It is essential to follow the flushing frequency and the trend of DP build-up, to react on time when an un-usual change is recognized.

It is recommended to include the filters in the routine equipment inspection "tours" of the plant, and to treat any leakage or damage as early as possible.

Routine inspection

Initiate flush cycle by closing the 1/4" valve at the low-pressure sensing port of the pressure differential switch for 5 seconds. Verify that the exhaust valve opens, that the scanner moves properly and stop when it reaches the limit switch - verify that the exhaust valve closes.

Weekly or bi-weekly maintenance

- Inspect the filter as described above.
- Check that there is grease on the drive shaft, and drive bushing. Add grease if necessary.
- Check for any leakage from the scanner shaft. If necessary, replace the Shaft Sealing Assembly (8).

Annual maintenance

A thorough overhaul maintenance is recommended once every year or when the filter has completed about 50,000 flush cycles.

Before beginning any maintenance procedure, carefully read the safety instructions and make sure that the staff is fully aware of and comply with these and any other relevant local safety instructions.

The thorough maintenance operation will include the following:

1. Filter disassembly.
2. Visual inspection and evaluation of screen.
Thorough cleaning instructions can be found below. Replacement is required only if there are signs of mechanical damage to the screen.
3. Replacement of the SLN CAP (24) + SLN seals (107&108) as preventive maintenance.
4. Replacement of the Shaft Sealing Assembly (26) as preventive action or in case of significant leaking from its drain tube.
5. Replacement of seals and O-rings as required.
6. Filter re-assembly.
7. Restart the filter as per instructions given in this manual.

Spare parts Kits for annual maintenance are available, as per the following table:

CAT. NO.	DESCRIPTION
700194-000050	SAF-X 1500 SLN SCANNER PREVENTIVE MAINTENANCE ONE YEAR
700194-000051	SAF-X 3000 SLN SCANNER PREVENTIVE MAINTENANCE ONE YEAR
700194-000052	SAF-X 4500 SLN SCANNER PREVENTIVE MAINTENANCE ONE YEAR
700194-000053	SAF-X 1500 STD SCANNER NOZZLES PREVENTIVE MAINTENANCE ONE YEAR
700194-000054	SAF-X 3000 STD SCANNER NOZZLES PREVENTIVE MAINTENANCE ONE YEAR
700194-000055	SAF-X 4500 STD SCANNER NOZZLES PREVENTIVE MAINTENANCE ONE YEAR

Each Kit contains the following items:

SLN PREVENTIVE MAINTENANCE ONE YEAR			QTY. PER SAF-X MODEL		
ITEM NO.	CAT. NO.	DESCRIPTION	1500	3000	4500
26	700190-006190	SAF SHAFT SEALING ASSEMBLY	1	1	1
24+108	700190-002400	SLN CAP ASSEMBLY (+O-RING)	2	4	6
107	710101-001281	SLN SEAL 16 MM TPU	4	8	12
36	760105-000097	CLEVIS PIN 3/16" X 1-1/16"	2	2	2
37	760105-000052	PIN COTTER 3/64 X 5/8 MM	2	2	2
ML-2	760190-000127	TUBE OF GREASE PG-21	1	1	1
ML-3	760190-000097	SPANJAARD NON-MELTING GREASE 100 GM TUBE	1	1	1

STD SCANNER NOZZLES PREVENTIVE MAINTENANCE ONE YEAR			QTY. per SAF-X model		
ITEM NO.	CAT. NO.	DESCRIPTION	1500	3000	4500
26	700190-006190	SAF SHAFT SEALING ASSEMBLY	1	1	1
16+17	710101-000922	MOLDED SCANNER NOZZLE - PART 1 + 2	2	4	6
222	760101-000537	PHILLIPS PAN TAP SCREW PT4X20	8	16	24
36	760105-000097	CLEVIS PIN 3/16" X 1-1/16"	2	2	2
37	760105-000052	PIN COTTER 3/64 X 5/8 MM	2	2	2
ML-2	760190-000127	TUBE OF GREASE PG-21	1	1	1
ML-3	760190-000097	SPANJAARD NON-MELTING GREASE 100 GM TUBE	1	1	1

Screen COP (Clean-Out-of-Place)

Screen cleaning is required as part of the maintenance procedure or in case the filtration system is significantly clogged. In most cases cleaning with high pressure washer is sufficient.

- a) Wash the Screens with high pressure washer.
- b) Rinse the Screens from outside-in, and then rinse their interior surface.
- c) Check the Screens for clogged surface and any mechanical damage, using a strong flashlight.

Mineral Scaling/precipitation:

If the Screen is clogged with scale or precipitants that cannot be removed by the pressure washing, chemical treatment is required.

Chemical or detergent selection depends on precipitants origin - Mineral or Organic.

Acid treatment:

Used for dissolving Calcium Carbonate, Magnesium Carbonate compounds, Iron and Manganese Oxides.

Most of the mineral acids are suitable for the treatment (as long as they do not contain gypsum). The common ones are:

- Hydrochloric acid (HCL)
- Sulfuric acid (H₂SO₄)

It is recommended to dilute the acid to a concentration of about 2% in which case the acid is still effective but is less dangerous.

Remove the seals from the Screen cylinder and soak it in the solution for 10 – 20 minutes (depending on the amount and kind of precipitates).

The Screen should then be checked, if the Screen is not clean, continue with the process for additional 10 – 20 minutes.

If the Screen is clean, wash it thoroughly with clean water.

Organic and Biofilm Removal:

Organic Compounds and Biofilm can be cleaned with Sodium Hypochlorite (NaClO) solution or Calcium chlorite (CaClO₂) at 0.5%, for about 2 minutes. If the Screen is not clean, continue with the process for additional 2 minutes.

If the Screen is clean, wash it thoroughly with clean water.

WARNING! *The above chemicals are harmful to people and equipment. Read and follow manufacturer's instructions and MSDS. Use ALL precautions and protective gear when working with the Chemicals to prevent contact with skin, eyes & mouth.*

Dismantling and Assembling the Filter Components

Dismantling:

- Prior to opening the filter, perform flush cycle by pressing the "TEST" push button.
- Close the filter inlet and outlet valves and open the drain valve to release the pressure and drain the filter.
- Turn off the power and secure the main-switch.
- Release the lid bolts (200) from their nuts and open the front lid (2).
- Pull the Coarse Screen Assembly (8) out of the filter housing.
- Pull the fine Screen Element (10) out of the filter housing.
- Release bolts 221 and remove the Side Covers (29).
- Pull out the Pin Cotter (37) from the Clevis Pin (36) – at the filter housing side.
- Pull out the Clevis Pin (36) to disconnect the scanner from the Drive Shaft.
- Pull the Scanner out of the filter (11 or 18).

Assembly:

1. Insert the Suction Scanner into its place and lock it with the Pins 36 & 37.
- Verify that the hydraulic seals are properly mounted on the fine Screen Element (10). Lubricate the seals with some silicone lubricant (ML-2 or ML-4).
 - Insert the screen into the filter housing (1). Note the triangle mark on the screen edge. It must point upward in order to lock the screen in its place and prevent it from turning during flushing.
 - Verify that the hydraulic seal is mounted on the Coarse Screen Assembly (8). Lubricate it with some silicone lubricant (ML-2 or ML-4).
 - Insert the Coarse Screen Assembly (8) and verify it is properly fits.
 - Verify that the Lid O-ring (100) is in place.
 - Close the filter front lid and tighten its bolts (200) in even manner.
 - Re-connect the power and run a dry flush cycle. Verify all is working good mechanical aspect.
 - Open the filter inlet valve and gradually fill the filter with water. Check and attend any leak.
 - Run a few flush cycles. Verify all is working well.
 - Gradually open the outlet valve and bring the filter back in service.

Removing the Seals-Sleeve:

1. Removing the Seals-Sleeve (7) is not required for standard service.
In order to take it out, first remove the lid's O-Ring (100) and then pull out the Sleeve by holding its internal edge.
2. Replacement of the hydraulic seals of the Seals-Sleeve (101) and/or the Screen Element (104) is required only in case it is damaged.
Use Seal Extractor (TL-01) or flat screwdriver to remove the seal from its seat.
3. Make sure to properly mount the new seal in its seat.
Lubricate the seal with silicone lubricant (ML-2 or ML-4). When insert it back, make sure that the sign TOP is pointing up.
4. Put back the Lid's O-Ring Before closing the filter's front lid.

Changing the Shaft Sealing Assembly:

1. Changing the Shaft Sealing Assembly (26) is recommended as preventive maintenance or when it is significantly leaking.
2. Dismantle the filter and pull out the suction scanner (see above instructions).
3. Remove the Bearing Stopper (27)
4. Remove the small drainage tube.
5. Use open wrench #41 or big adjustable wrench to screw out the bearing.
6. Change the O-ring (106) if required.
7. Screw back a new bearing, carefully tighten it until the drain port pointing down.
8. Put back the drainage tube and lock the bearing position with the stopper.

Note: The Shaft Sealing Assembly is replaced as one piece. It is impossible to change any of its internal parts and seals.

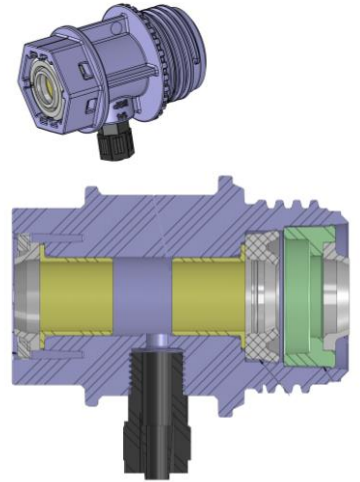

Removing the drive unit:

1. Close the inlet and outlet valves of the filter and release pressure.
2. Disconnect power supply.
3. Remove the drive shaft cover (39) by unscrewing bolts 215.
4. Remove the drive unit (311&312) by unscrewing bolts 211 and their nuts (214). note the drive shaft key 33, it may fall out of the gearbox (311).
Note: It is recommended that the power cable of the motor will be long enough to allow removing of the drive unit and put is nearby without disconnecting the cable.
5. At this stage it is possible to adjust the Limit Switches (315) position by manually turning the drive shaft by means of 17 mm wrench.
6. Re-assemble in reverse order. Verify the existence of the drive shaft key. Lubricate the drive shaft (32) and gearbox (311) with Multi-Purpose Grease (ML-03).

Limit Switches adjustment:

1. Remove the drive unit (311&312) as described above.
2. Slightly release bolts (216) and slide the **inner limit switch** (315) toward the filter body.
3. Turn the drive shaft inward (CW) till the end and then back 3/4 of a turn.
4. Slide the limit switch backward until hearing the switching "click". Use multi-tester to verify the exact contact point.
It is possible also to watch the input LED indicators in the PLC to recognize the contact.
5. Tighten the bolts (216) and repeat the test once again.
6. Slightly release bolts (216) and slide the **outer limit switch** (315) toward the drive unit.
7. Turn the drive shaft outward (CCW) till the end and then back 3/4 of a turn.
8. Slide the limit switch forward until hearing the switching "click". Use multi-tester to verify the exact contact point.
It is possible also possible to watch the input LED indicators to recognize the contact.
9. Tighten the bolts (216) and repeat the test once again.

Note: The limit switches are NC (normally closed), that means that when the switch is activated the signal is zero (0) and when it is not activated, the signal is one (1).

Restarting the filter

1. Double check and re-tighten the lid bolts and any other relevant bolts that might became loose.
2. Clean the working area and remove any unused parts and tools from the vicinity.
3. Connect power supply to the filter and open the relevant switches.
4. Initiate a few “dry” cycles. Verify proper movement of the scanner and opening of the flush valve.
5. Gradually open Inlet valve and fill the filter with water.
6. Initiate a few flush cycles. Check and fix any leaking and verify proper movement of the scanner.
7. Re-assemble the side covers.
8. Open outlet valve gradually and bring the filter to its normal service conditions.

Winterization Procedure:

This section is relevant for installations which are exposed to freezing conditions during winter while the filter is not in use.

If the filter supposed to be in operation under freezing risk conditions, thermal isolation and heat tracing must be considered.

1. Close isolation outlet valve and initiate a few flush cycles.
2. Close isolation inlet valve and open the Drain valve.
3. Disconnect power at the middle of a flush cycle, so shaft is in the middle of its travel.
4. drain any instrumentation which is mounted on the filter by removing its pilot tubes.
Re-connect all tubes after the instrument and the tubes are drained. (Pressure transmitters, solenoids, valves etc.).
5. Remove the shafts cover (39) and side covers (29) and apply some grease (ML-3) on the drive shaft.
Put back the covers afterwards.
6. Wrap and tie a thick PE sheet over the drive unit assembly (311&312) for extra protection.
7. For re-start the filter, remove all PE sheets, and follow the startup instructions as described in this manual.

16. Troubleshooting

Malfunction	Possible Cause	Corrective Action
High DP + Continuous Flushing	Extreme load of suspended solids.	<ol style="list-style-type: none"> 1. Close downstream valve and initiate 3-5 consecutive flush cycles. 2. Switch to continuous flushing mode (if applicable) and gradually open downstream valve. 3. Watch the DP, if stable – try to return to normal operation mode.
	Too high flow rate	<ul style="list-style-type: none"> • Reduce Flow
	Too low working Pressure.	<ol style="list-style-type: none"> 1. Check Inlet and outlet pressure. 2. Make sure working pressure is above 2.0 bar and DP is not more than 0.5 bar. 3. Close downstream valve in order to eliminate the differential pressure.
	Flushing valve did not open.	<ul style="list-style-type: none"> • Verify that flushing valve is open and there is no interruption to the flushing flow.
High DP + No Flushing	No power.	<ul style="list-style-type: none"> • Verify Power supply.
	Filter is in high DP fault mode.	<ul style="list-style-type: none"> • Check the control system. RESET any potential Fault.
High DP or Flow reduction + No flushing	DP switch is not reacting.	<ul style="list-style-type: none"> • Check DP switch (Transmitter or switch) for fault or clogging. If switch is out of order it is possible to work according to short time intervals.
Motor Overload	Too high mechanical resistance.	<ol style="list-style-type: none"> 1. Remove the side covers and check for mechanical damages. 2. Remove the drive unit and check if the motor is running without load. 3. Try turning the drive shaft by means of a proper wrench. 4. Reset the motor protector and check the current consumption. <p>If problem cannot be solved:</p> <ol style="list-style-type: none"> 1. Disassemble the filter according to "Maintenance" Chapter. 2. Inspect its internals. 3. Perform SLN nozzle inspection. 4. Re-Assemble the filter. <p>Do not force the motor by increasing the Ampere setting above the nominal motor rating!</p>
Limit switch Fault	Both limit-switches are OFF.	<p>Check the limit switch wiring at the junction box and the control panel.</p> <p>Change limit switch if required</p>
Motor Time Out	Limit switches malfunction	<p>Check the limit switch positioning.</p> <p>Re-adjust the limit switches if required.</p> <p>Replace switch if needed.</p>
	Drive bushing worn out or drive key is broken	<p>Check the drive unit, look for mechanical problem. Check the drive bushing – replace if required.</p>
Direction Fault - Motor is running inward (CW) and a signal is received from outer limit switch.	<p>Wrong rotation direction of the motor due to wrong phase order.</p> <p>Or</p> <p>Wrong wiring of the limit switches.</p>	<ul style="list-style-type: none"> • Check and correct wiring.

17. Amiad Limited Warranty

1. This certificate applies to Amiad Water Systems Ltd. ("Amiad") products purchased by you (the "Buyer") from Amiad unless specifically agreed otherwise in writing by Amiad. This Warranty extends only to the original purchaser, and is not transferable to anyone who subsequently purchases, leases, or otherwise obtains the product from the original purchaser.
2. Amiad hereby warrants that the products are and will be free from defects in material and workmanship under normal use and service. Amiad warrants that it will correct manufacturing defects in the products, in accordance with the conditions set out in this Warranty.
3. This Warranty is enforceable for a period of 12 months after the date upon which the products were delivered (the "**Warranty Period**").
4. In the event that during the Warranty Period the Buyer discovers a defect in material and/or workmanship in any product or part (the "**Defective Product**"), it shall submit a written complaint to Amiad using Amiad's standard Buyer Complaint Form. For the receipt of the Buyer Complaint Form, the submission of the complaint or any questions please contact your service representative.
5. Upon written demand by Amiad the Buyer shall return the Defective Product - or a sample thereof - to Amiad, at Amiad's cost. If the Buyer ships any such Defective Product, Amiad suggests the Buyer package it securely and insure it for value, as Amiad assumes no liability for any loss or damage occurring during shipment. Provided however that in the event Amiad determines that this Warranty does not apply to such product, Buyer shall promptly reimburse Amiad for such cost (including freight and customs). Any returned product or part must be accompanied by the Warranty certificate and the purchase invoice. It is clarified that the Buyer may not return the Defective Product unless such return was coordinated and approved by Amiad in advance.
6. Amiad's obligation under this Warranty shall be limited to, at Amiad's option, the repair or exchange, free of charge, of the product or any part which may prove defective under normal use and service during the Warranty Period. The provision of a repair or replacement of a product during the Warranty Period will result in an extension of the Warranty Period by an additional period of 12 months, provided that the total accumulated Warranty Period shall in any event be no more than 18 months from the date upon which the products were delivered.
7. This Warranty is valid on the condition that the products are installed according to Amiad's instructions as expressed in Amiad's instruction manuals and according to the technical limitations as stipulated in Amiad's literature or as stated by a representative of Amiad.
8. This Warranty will not apply to damaged or defective products resulting from or related to:
 - (i) Fire, flood, power surges or failures or any other catastrophe and/or unforeseen occurrence, such as but not limited to those for which the Buyer is customarily insured for, or any force majeure events;
 - (ii) Fault, abuse or negligence of the Buyer;
 - (iii) Intake water not meeting the agreed standards, as set forth in a written document, approved by Amiad, or improper storage;
 - (iv) Improper or unauthorized use of the product or related parts by the Buyer, including Buyer's failure to operate the product in conformity with the recommendations and instructions of Amiad, as set forth in Amiad's manuals and other written materials, the operation of the product other than by a trained and qualified operator, or improper installation of the product by a third party not authorized by Amiad;
 - (v) Performance by the Buyer of maintenance or operation other than in conformity with the recommendations and instructions of Amiad, or other than in accordance with procedures defined in the literature supplied for products (including the timely replacement of requisite parts), and for services provided other than by a trained and qualified advanced operator; or
 - (vi) Any alteration, modification, foreign attachment to or repair of the products, other than by Amiad or its authorized technical representatives.
9. In no event shall Amiad be liable to the Buyer or any third party for any damages to property, or for any intangible or economic loss, including loss of profits, loss of customers or damage to reputation, for any damages, including indirect, special, consequential damages, or punitive damage arising out of or in connection with this Warranty, or arising out of or in connection with the product's performance or failure to perform, even if it has been advised of the possibility of such damages.
10. Amiad will be excused for failure to perform or for delay in performance hereunder if such failure or delay is due to causes beyond its reasonable control or force majeure preventing or hindering performance.
11. This Warranty set forth herein is the only contractual warranty given by Amiad and is provided in lieu of any other warranties created by any documentation, packaging or otherwise.
12. Amiad makes no warranty whatsoever in respect to accessories or parts not supplied by Amiad. In the event that Amiad is required to correct a Defective Product or product not covered by this Warranty, it will do so solely in consideration for additional fees.
13. The parties will actively endeavor to amicably settle any dispute arising between them. In the event that the parties are unable to reach an equitable settlement of such dispute, any claim or lawsuit related to the Warranty, its validity execution, its performance be brought before only the courts of Tel-Aviv, Israel. Israeli law will govern the Warranty, to the exclusion of any conflict of law rules.

Алматы (7273)495-231
Ангарск (3955)60-70-56
Архангельск (8182)63-90-72
Астрахань (8512)99-46-04
Барнаул (3852)73-04-60
Белгород (4722)40-23-64
Благовещенск (4162)22-76-07
Брянск (4832)59-03-52
Владивосток (423)249-28-31
Владикавказ (8672)28-90-48
Владимир (4922)49-43-18
Волгоград (844)278-03-48
Вологда (8172)26-41-59
Воронеж (473)204-51-73
Екатеринбург (343)384-55-89

Иваново (4932)77-34-06
Ижевск (3412)26-03-58
Иркутск (395)279-98-46
Казань (843)206-01-48
Калининград (4012)72-03-81
Калуга (4842)92-23-67
Кемерово (3842)65-04-62
Киров (8332)68-02-04
Коломна (4966)23-41-49
Кострома (4942)77-07-48
Краснодар (861)203-40-90
Красноярск (391)204-63-61
Курск (4712)77-13-04
Курган (3522)50-90-47
Липецк (4742)52-20-81

Магнитогорск (3519)55-03-13
Москва (495)268-04-70
Мурманск (8152)59-64-93
Набережные Челны (8552)20-53-41
Нижний Новгород (831)429-08-12
Новокузнецк (3843)20-46-81
Ноябрьск (3496)41-32-12
Новосибирск (383)227-86-73
Омск (3812)21-46-40
Орел (4862)44-53-42
Оренбург (3532)37-68-04
Пенза (8412)22-31-16
Петрозаводск (8142)55-98-37
Псков (8112)59-10-37
Пермь (342)205-81-47

Ростов-на-Дону (863)308-18-15
Рязань (4912)46-61-64
Самара (846)206-03-16
Санкт-Петербург (812)309-46-40
Саратов (845)249-38-78
Севастополь (8692)22-31-93
Саранск (8342)22-96-24
Симферополь (3652)67-13-56
Смоленск (4812)29-41-54
Сочи (862)225-72-31
Ставрополь (8652)20-65-13
Сургут (3462)77-98-35
Сыктывкар (8212)25-95-17
Тамбов (4752)50-40-97
Тверь (4822)63-31-35

Тольятти (8482)63-91-07
Томск (3822)98-41-53
Тула (4872)33-79-87
Тюмень (3452)66-21-18
Ульяновск (8422)24-23-59
Улан-Удэ (3012)59-97-51
Уфа (347)229-48-12
Хабаровск (4212)92-98-04
Чебоксары (8352)28-53-07
Челябинск (351)202-03-61
Череповец (8202)49-02-64
Чита (3022)38-34-83
Якутск (4112)23-90-97
Ярославль (4852)69-52-93

Россия +7(495)268-04-70

Казахстан +7(7172)727-132

Киргизия +996(312)96-26-47

<https://amiad.nt-rt.ru> || afv@nt-rt.ru