

Алматы (7273)495-231
Ангарск (3955)60-70-56
Архангельск (8182)63-90-72
Астрахань (8512)99-46-04
Барнаул (3852)73-04-60
Белгород (4722)40-23-64
Благовещенск (4162)22-76-07
Брянск (4832)59-03-52
Владивосток (423)249-28-31
Владикавказ (8672)28-90-48
Владимир (4922)49-43-18
Волгоград (844)278-03-48
Вологда (8172)26-41-59
Воронеж (473)204-51-73
Екатеринбург (343)384-55-89

Иваново (4932)77-34-06
Ижевск (3412)26-03-58
Иркутск (395)279-98-46
Казань (843)206-01-48
Калининград (4012)72-03-81
Калуга (4842)92-23-67
Кемерово (3842)65-04-62
Киров (8332)68-02-04
Коломна (4966)23-41-49
Кострома (4942)77-07-48
Краснодар (861)203-40-90
Красноярск (391)204-63-61
Курск (4712)77-13-04
Курган (3522)50-90-47
Липецк (4742)52-20-81

Магнитогорск (3519)55-03-13
Москва (495)268-04-70
Мурманск (8152)59-64-93
Набережные Челны (8552)20-53-41
Нижний Новгород (831)429-08-12
Новокузнецк (3843)20-46-81
Ноябрьск (3496)41-32-12
Новосибирск (383)227-86-73
Омск (3812)21-46-40
Орел (4862)44-53-42
Оренбург (3532)37-68-04
Пенза (8412)22-31-16
Петрозаводск (8142)55-98-37
Псков (8112)59-10-37
Пермь (342)205-81-47

Ростов-на-Дону (863)308-18-15
Рязань (4912)46-61-64
Самара (846)206-03-16
Санкт-Петербург (812)309-46-40
Саратов (845)249-38-78
Севастополь (8692)22-31-93
Саранск (8342)22-96-24
Симферополь (3652)67-13-56
Смоленск (4812)29-41-54
Сочи (862)225-72-31
Ставрополь (8652)20-65-13
Сургут (3462)77-98-35
Сыктывкар (8212)25-95-17
Тамбов (4752)50-40-97
Тверь (4822)63-31-35

Тольятти (8482)63-91-07
Томск (3822)98-41-53
Тула (4872)33-79-87
Тюмень (3452)66-21-18
Ульяновск (8422)24-23-59
Улан-Удэ (3012)59-97-51
Уфа (347)229-48-12
Хабаровск (4212)92-98-04
Чебоксары (8352)28-53-07
Челябинск (351)202-03-61
Череповец (8202)49-02-64
Чита (3022)38-34-83
Якутск (4112)23-90-97
Ярославль (4852)69-52-93

Россия +7(495)268-04-70

Казахстан +7(7172)727-132

Киргизия +996(312)96-26-47

<https://amiad.nt-rt.ru> || afv@nt-rt.ru

AMIAD Water Systems

SAF-1500 FILTER

Serial number:	_____
Order number:	_____
Catalog number:	_____
Filtration degree:	_____
Tested by:	_____

Installation, Operation and Maintenance Instructions



AMIAD Water Systems

SAF-1500 FILTER – User Manual

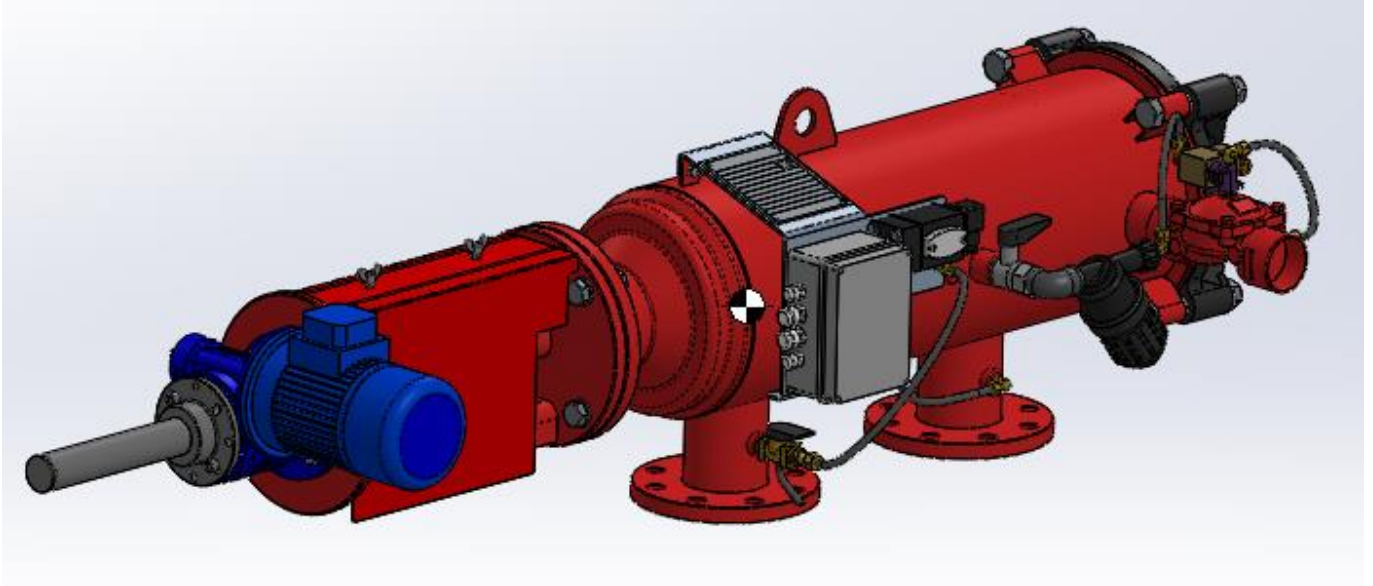

TABLE OF CONTENTS

SAF-1500 FILTER – User Manual	2
TECHNICAL SPECIFICATIONS	4
General	4
Flushing data.....	4
Control and electricity	4
Construction materials	4
Standard filtration degrees.....	4
SAFETY INSTRUCTIONS	5
General Safety Instructions	5
Installation	5
Commissioning.....	6
Operation and Control.....	6
Maintenance.....	7
DIMENSIONAL AND RECOMMENDED INSTALLATION DRAWING	8
DIMENSIONAL DRAWING – Standard SAF 1500	8
DESCRIPTION OF FILTER OPERATION.....	10
INSTALLATION.....	12
MAINTENANCE	14
DISMANTLING AND ASSEMBLING THE FILTER COMPONENTS	16
PARTS LIST – Standard SAF-1500.....	18
PARTS DRAWING - Standard SAF-1500 Section 1: Page 1	20
PARTS DRAWING - Standard SAF-1500 Section 1: Page 2	20
PARTS SCHEDULE & DRAWING – Standard SAF-1500 Filter	21
Section 2: Drive Shaft Housing.....	22
PARTS SCHEDULE & DRAWING – Standard SAF-1500 Filter Section 3: Scanner.....	23
PARTS SCHEDULE & DRAWING - Standard SAF-1500 Filter Section 3: SLN Scanner.....	24
AMIAD LIMITED WARRANTY.....	25

With any inquiry please quote Filter Serial Number, located on the filter housing.

TECHNICAL SPECIFICATIONS

General

Maximum flow rate	80 m ³ /h	350 USgpm	Consult manufacturer for optimum flow depending on filtration degree & water quality.
Min. working pressure	1.5 bar	21 psi	or lower if pressure is increased for flushing
Max. working pressure	10 bar	150 psi	16 bar = 240 psi upon request
Filter area	1,500 cm ²	233 in ²	
Inlet/Outlet diameter	50,80,100 mm	2", 3", 4"	Flange / Threads standards as per request.
Filter housing diameter	250 mm	10"	Epoxy-coated steel, or other on request.
Max. working temp.	80°C	176°F	
Weight	50 mm (th)= 82 Kg 50 mm (fl)= 84 Kg 80 mm = 85 Kg 100 mm = 88 Kg	2"(th) = 181 lb. 2"(fl) = 185 lb. 3" = 190 lb. 4" = 194 lb.	

Flushing data

Exhaust valve	50 mm	2"	
Flushing cycle time	15 seconds	15 seconds	
Flushing water per cycle	25 liter	6.6 gallon	at 2 bar (30 psi)
Minimum flow for flushing	6 m ³ /h	26 USgpm	at 2 bar (30 psi)

Control and electricity

Control voltage	24V AC (12V or 24V DC upon request)
Electric motor	1/4 HP 50 / 60 Hz, 35 / 42 Gear output R.P.M.
Rated operation voltage	3 phase 220 / 380 / 440 V, 50 / 60 Hz Single phase 110 / 220 V, 50 / 60 Hz DC 12V or 24V (upon request)
Current consumption	0.6 Amp. (with 3 phase 380 / 440 V)

Construction materials

Filter housing and lid	Epoxy-coated carbon steel 37-2 (Stainless Steel 316 available on request).
Screens	Stainless Steel 316
Cleaning mechanism	Stainless Steel 316, POM, PVC
Exhaust valve	Epoxy-coated cast iron, Natural Rubber
Seals	Synthetic Rubber
Control system	Aluminum, Brass, Stainless Steel, PVC

Standard filtration degrees

		Stainless Steel Weave Wire Screen							
micron	500	300	200	130	100	80	50	20	10
mm	0.5	0.3	0.2	0.13	0.1	0.08	0.05	0.02	0.01

SAFETY INSTRUCTIONS

General Safety Instructions

- Amiad filtration products always operate as components in a larger system. It is essential for the system designers, installers and operators to comply with all the relevant safety standards.
- Prior to installation, operation, maintenance or any other type of action carried out on the filter, read carefully the safety, installation and operation instructions.
- During installation, operation or maintenance of the filter all conventional safety instructions should be observed in order to avoid danger to the workers, the public or to property in the vicinity.
- Please note: The filter enters into a flushing mode automatically, without prior warning.
- No change or modification to the equipment is permitted without a written notification given in advance by the manufacturer or by its representative, on the manufacturer's behalf.
- Always observe standard safety instructions and good engineering practices whilst working in the filter's vicinity.
- Use the filter only for its intended use as designed by Amiad, any misuse of the filter may lead to undesired damage and may affect your warranty coverage. Please consult with Amiad prior to any non-regular use of this equipment.

Installation

General

- Install the filter according to the detailed Installation Instructions provided with the filter by the manufacturer and according to the description given in this manual.
- Make sure to leave enough clearance so as to enable easy access for future treatments and safe maintenance operations.
- The user should arrange suitable lighting at the area of the filter to enable good visibility and safe maintenance.
- The user should arrange suitable platforms, ladders and safety barriers to enable easy and safe access to the filter without climbing on pipes and other equipment. The user should verify that any platform, barrier, ladder or other such equipment is built, installed and used in accordance with the relevant local authorized standards.
- Check and re-tighten all bolts during commissioning and after the first week of operation.
- Use only appropriate standard tools and equipment operated by qualified operators when installing, operating and maintaining the filter.
- When installation is required in hazardous environment sites, underground or high above ground, make sure that the site design and the auxiliary equipment are appropriate and that installation procedures are carried out in accordance with the relevant standards and regulations.
- Ensure walking areas about the installation are slip free when wet.

Shipment and transporting

- Shipping and transporting the filter must be done in a safe and stable manner and in accordance with the relevant standards and regulations.
- For shipping, lifting and positioning the filter, use only approved lifting equipment and authorized employees and contractors.

Electricity

- Electric wiring should be performed by an authorized electrician only, using standardized and approved components.
- Install a **lockable** main power cut-off switch close to the control panel.
- If due to site constraints, the control panel is installed without a clear line-of sight of the filter, an additional **lockable** power disconnect cut-off switch should be installed near each filter unit.
- Installation of the filter should be performed so as to avoid direct water splashing on the electrical components or on the control panel.

Pneumatics

- Install a **lockable** main cut-off switch, **featured with a pressure release mechanism**, on the compressed air supply line close to the control panel.
- If the control panel is installed far away and there is no eye contact with the filter, a **lockable** compressed air cut-off switch, **featured with a pressure release mechanism**, should be installed near each filter unit.
- The user should make sure that the compressed air supplied to the filter never exceeds the maximum designated pressure for this filter. An air-pressure reduction valve should be installed on the compressed air supply line upstream of the filter's pneumatic inlet port.

Hydraulics

- Extra safety devices should be installed on hot water applications to avoid skin burn danger.
- The user should install a manual Water Cut-off Valve next to the filter's inlet port.
- In cases where the downstream piping network downstream of the filter is pressurized an additional manual Water Cut-off Valve should be installed next to the filter outlet port.
- The user should make sure that the system includes a Pressure Release / Drainage Valve to enable release of residual pressure prior to any maintenance procedure performed on the filter.
- The user should make sure that the filter is never exposed to water pressure exceeding the maximum designated pressure for this filter, if needed a Pressure Reduction Valve should be installed upstream of the filter's water inlet port.
- Please note that the maximum working pressure indicated at the filter's specifications table includes the pressure caused by fluid hammer and pressure surge effects.

Civil Engineering

- Make sure that the filter installation is done by Amiad qualified technicians.
- Make sure that any civil engineering work at the installation site such as construction, lifting, welding, etc. is done by qualified workers / technicians / contractors and in accordance with the relevant local standards.
- While using lifting equipment, make sure that the filter or the lifted part is chained securely and in a safe manner.
- Do not leave lifted equipment if there is no necessity. Avoid working below lifted equipment.
- Wear a safety helmet while using lifting equipment.
- Make sure that the flooring is sloped for drainage and to avoid accumulation of liquids.

Commissioning

- Read carefully the Commissioning and the First Start-up Operation instructions prior to any attempt to operate the filter.
- In order to achieve maximum performance and smooth operation of the filter it is crucial to perform the Startup and First Operation procedures exactly as described in this manual.
- Commissioning the filter should be done by an authorized Amiad technician, do not attempt to commission the filter unaccompanied since this may lead to undesired damage and may affect your warranty coverage.

Operation and Control

- Do not operate the filter before reading carefully and being familiar with its operation instructions.
- Observe the safety stickers on the filter and never perform any operation contradicting the instructions given.
- Never operate or use the filter for purposes other than its original design and operational envelope.

Maintenance

Before any maintenance or non-regular operation please read the following:

- Servicing the filter should be done only by technicians authorized by Amiad.
- Disconnect the filter from the power supply and lock the Main Power Switch.
- Disconnect the compressed air supply, release the residual pressure and lock the Pneumatics Main Valve.
- Disconnect the filter from the water system by closing and securing the Manual Inlet Valve. In cases where the downstream piping network is pressurized, close and secure the Manual Outlet Valve also.
- Release the residual water pressure by opening the Pressure Release / Drainage Valve.
- Empty the filter by opening the Drainage Valve.
- In hot water systems wait till the filter components cool off to a safe temperature.
- Place warning signs around the work area as required by the local standards and procedures.
- Inspect the filter's safety stickers and replace any damaged or faded sticker.

Mechanical

- When working on the filter use only appropriate standard tools.
- Always open and close valves slowly and gradually.
- Remove grease and fat material residues in order to avoid slipping.
- Before disconnecting the filter from the water supply, electricity and pneumatics and before releasing the filter's residual pressure do NOT:
 - loosen or unscrew bolts
 - remove any protection cover
 - open any service port flange
- Avoid splashing and water leakage so as to minimize slippage, electrification or damage to the equipment, caused by moisture.
- While using lifting equipment, make sure that the filter or the lifted part is chained securely and in a safe manner.
- Do not leave lifted equipment if there is no necessity. Avoid working below lifted equipment.
- Wear a safety helmet, goggles, gloves, and any other personal safety equipment required by the local standards and regulations.
- Human entry into a filter must be done in accordance with the relevant local safety instructions, standards and regulations for working in hazardous environment.
- Manual cleaning of filter media using high water pressure or steam should be performed in accordance with the cleaning system instructions, the local standards and regulations and without endangering the operator or the vicinity
- Manual cleaning of filter element using acid or other chemical agents should be performed in accordance with the relevant material safety instructions, the local standards and regulations and without endangering the operator or his vicinity.

Before returning to regular operation

- Re-assemble any protection covers or protection mechanisms removed during service or maintenance operations.
- Make sure that all the tools, ladders, lifting devices, etc. used during the maintenance procedures are taken away from the filter area and stored
- In order to return the filter to regular operation, follow the First Start-up Operation instructions as detailed in your user manual.
- For filters used in potable water systems it is required to disinfect the filter according to the local water authority standards and regulations before putting it back to service.

DIMENSIONAL AND RECOMMENDED INSTALLATION DRAWING

Drawing No. 1: Modular configuration

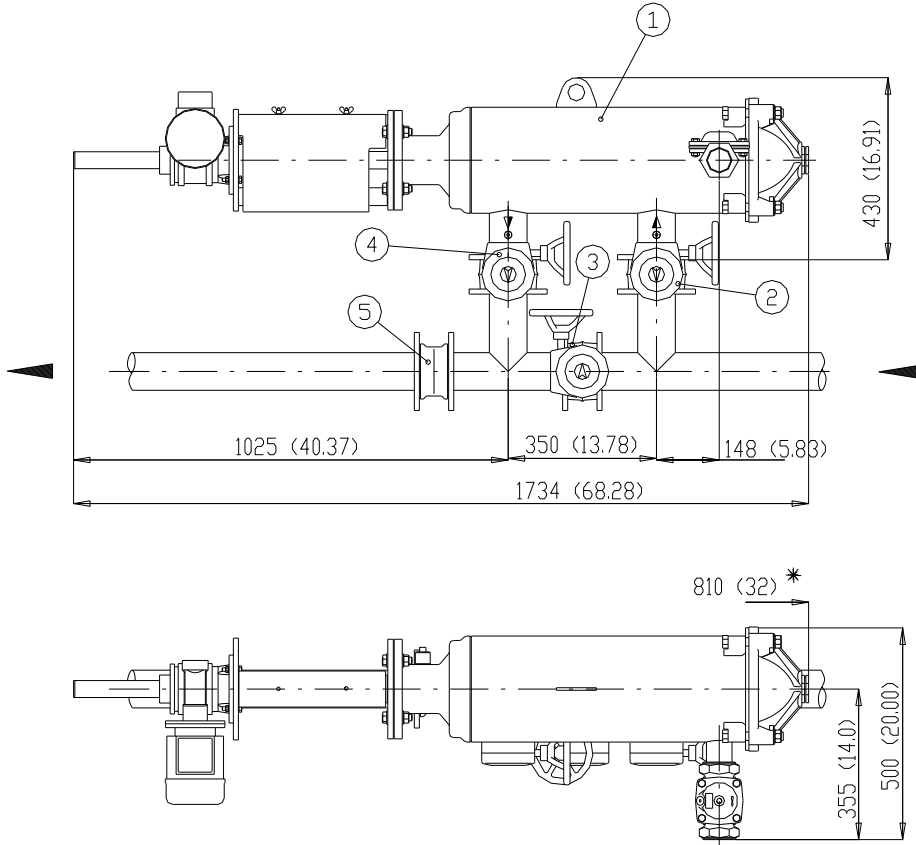

Key:

Dimensions: mm (inches)

1. 3" SAF 1500
2. 3" inlet butterfly valve
3. 3" by-pass valve
4. 3" downstream valve
5. 3" non-return check valve

* Minimum distance required for maintenance.

Drawing No. 2: In-line configuration

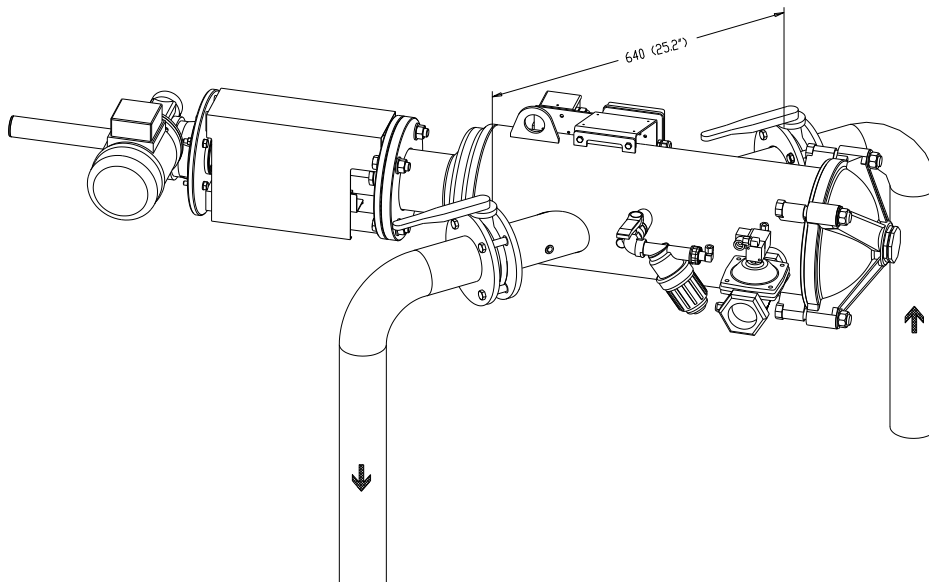

DIMENSIONAL DRAWING – Standard SAF 1500

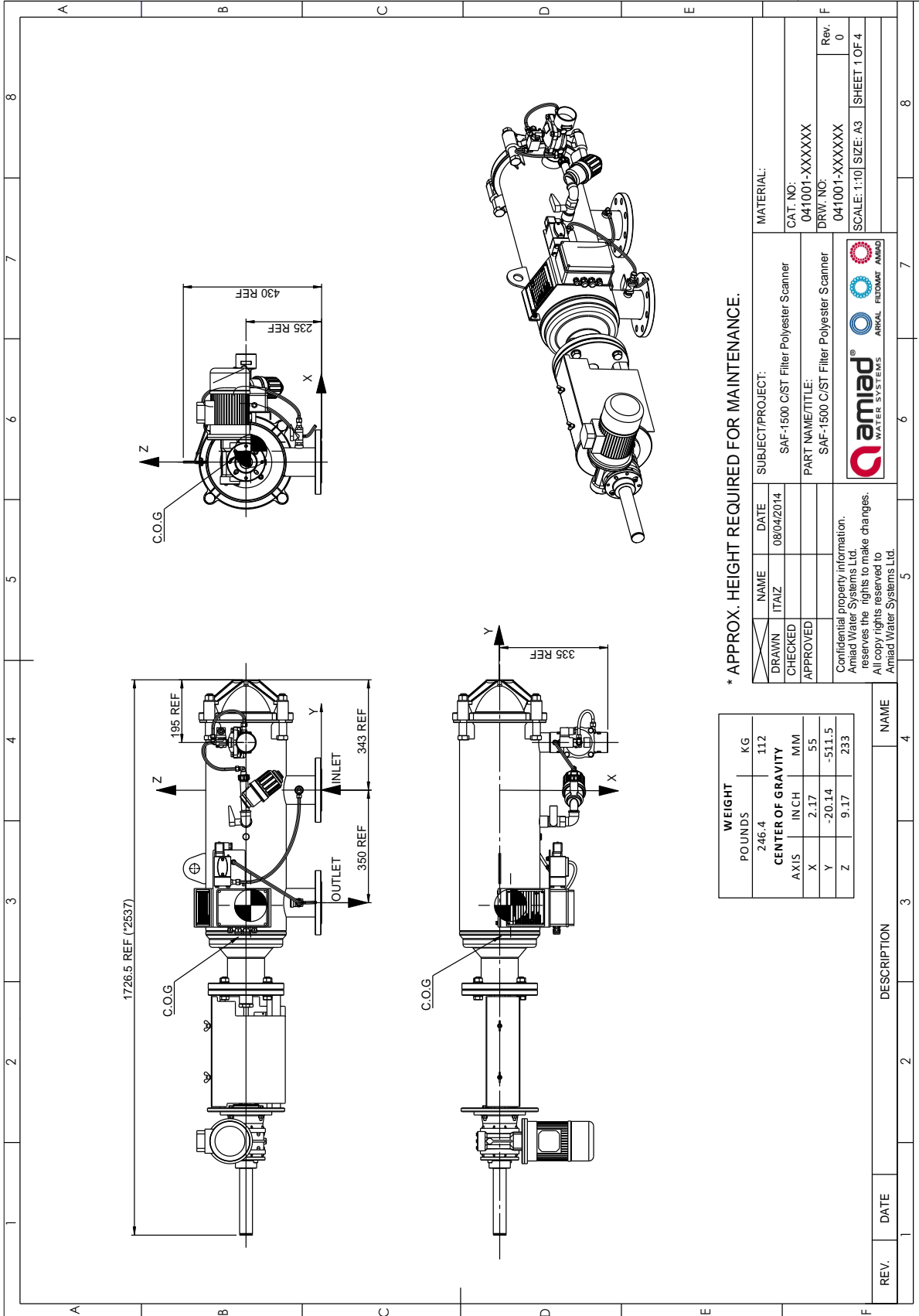





* APPROX. HEIGHT REQUIRED FOR MAINTENANCE.

WEIGHT		
POUNDS	KG	
246.4	112	
CENTER OF GRAVITY		
AXIS	INCH	MM
X	2.17	55
Y	-20.14	-511.5
Z	9.17	233

REV.	DATE	DESCRIPTION	NAME

DRAWN	NAME	DATE	SUBJECT/PROJECT:		MATERIAL:
CHECKED	ITAIZ	08/04/2014	SAF-1500 C/ST Filter Polyester Scanner		CAT. NO:
APPROVED			PART NAME/TITLE:		041001-XXXXXX
			SAF-1500 C/ST Filter Polyester Scanner		DRW. NO:
					041001-XXXXXX
					SCALE: 1:10
					SIZE: A3
					SHEET 1 OF 4
					Rev. 0

Confidential property information. Amiad Water Systems Ltd. reserves the rights to make changes. All copy rights reserved to Amiad Water Systems Ltd.		   
---	--	--

DESCRIPTION OF FILTER OPERATION

Filtering process:

The SAF-1500 is a sophisticated yet easy-to-operate automatic filter, with a self-cleaning mechanism driven by an electric motor. The SAF-1500 is designed to work with various types of screens in filtration degrees from 500 to 10 micron, and is available in 2", 3" and 4" inlet/outlet diameter.

The filter is available in "In-Line" configuration as well as in "Modular" configuration.

The water enters through the inlet pipe into the coarse screen from outside in, and through the fine screen from inside out. The "filtration cake" accumulates on the fine screen surface and causes head loss to develop.

The coarse screen is designed to protect the cleaning mechanism from large dirt particles. It should not accumulate large quantities of suspended solids and is not cleaned automatically.

Self-cleaning process:

The SAF 1500 will start the self-cleaning process when the pressure differential across the screen reaches a pre-set value or a predetermined lapse of time.

Cleaning of the filter element is carried out by the suction scanner which rotates in a spiral movement while removing the filtration cake from the screen and expels it out through the exhaust valve.

The rotation of the scanner is operated by a 2-way (fwd/rev) drive unit that is attached to the scanner by a threaded shaft which provides the linear movement.

The exhaust valve is activated for the duration of the cleaning cycle by a 3-way solenoid. During the self-cleaning process, which takes approximately 20 seconds, filtered water continues to flow downstream.

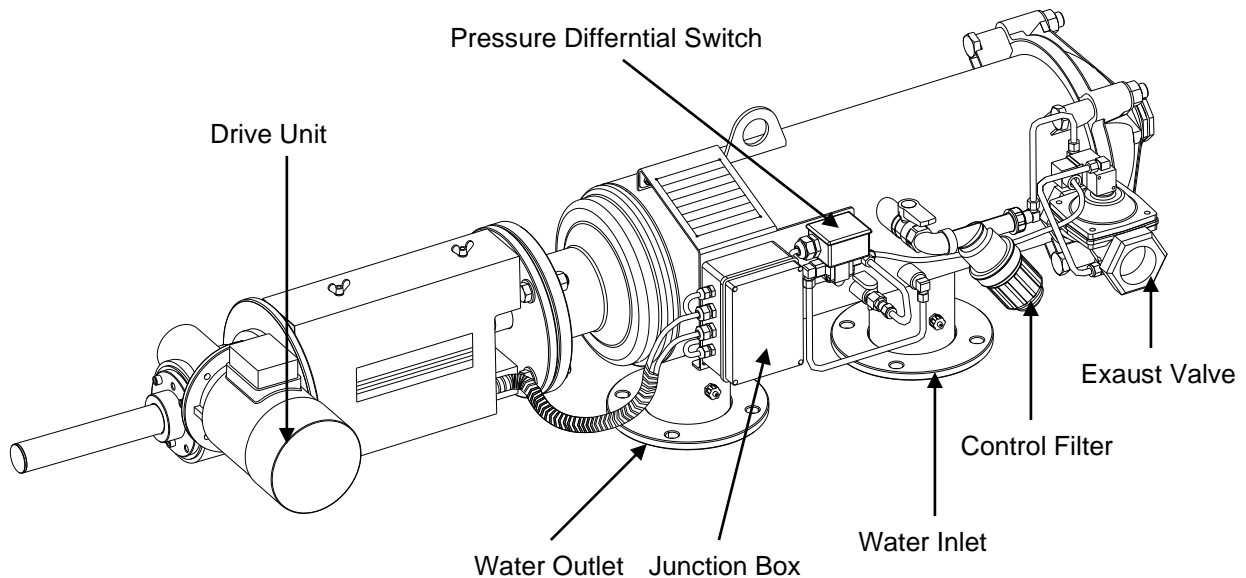

Different modes of filtration:

The filtration system may be found in one of the following modes:

- 1. Filtering mode:** This is the normal function condition. Flushing is not occurring and the power light on the control board is lit.
- 2. Flushing mode:** A mode in which the flushing process is in progress. The motor and exhaust valve are operating according to the program.
- 3. Continuous flushing mode:** It is possible to activate the self-cleaning mechanism continuously by changing the switch near the timer in the control board to "CONT." position.
- 4. Malfunction mode:** During malfunction mode the self-cleaning operation is stopped, the malfunction light on the control board is turned on and an external output is activated with 24V AC.

The filtration system may enter a malfunction mode in the following cases:

- 1st.** When there is a continuous signal from the pressure differential switch for a duration of more than the pre-set time. This means that the self-cleaning process is not successful.
- 2nd.** When the motor protector was activated, either manually or due to over load.
- 3rd.** As a result of a malfunction in the limit switches.

Initiation of self-cleaning:

The filter will enter the self-cleaning process as a result of any of the following causes:

1. A signal from the Pressure Differential Switch (PDS) - The PDS which is situated on the filter body, sends an electric signal when the pressure differential across the screen reaches the pre-set value (usually 0.5 bar =7 psi). The control board registers the signal and operates the flushing process according to its program.
2. Manually pressing the "TEST" push button at the control board.
3. The TIMER installed in the control board allows operation of self-cleaning process at time intervals that can be set up, independent from the head loss factor. The timer resets after every flushing cycle.
4. A signal from Continual flushing switch - This switch in the control board allows operation in continuous flushing mode; meaning, the filter is flushing itself all the time regardless of flow rate or water quality.

Control system:

Two types of control boards are available: PLC Type and Relay Type. See Appendix A or B for details.

INSTALLATION

Design recommendations:

1. If flow increases and pressure drops dramatically for a long period of time during network filling-up, it is recommended that a pressure sustaining valve is installed downstream. The pressure sustaining valve will ensure a controlled filling-up of the line.
2. If continual water flow is essential even during maintenance period, it is recommended that a manual or automatic by-pass is installed, and the isolating valves will be used to isolate each filter unit.
3. In places where there is an expected temporary worsening of water quality, it is possible to operate an emergency flushing program. In order to do so, a hydraulic controlled valve has to be installed downstream. For details, please consult the manufacturer.

Installation instructions:

1. Install the filter horizontally in a way which will allow convenient approach and enough space to dismantle the filter for maintenance purposes.
2. Ensure the direction of flow according to the arrows marked on the filter housing.
3. It is recommended to install a mechanical non-return valve downstream of the filter.
4. Connect a minimum of 2" pipe to the exhaust valve. The exhaust pipe should be designed so that it creates minimal resistance to flow of 6 m³/h (26 USgpm).
5. If the system is designed to operate with working pressure higher than 6 bar (85 psi), it is recommended that a manual valve is installed on the exhaust pipe, in order to enable regulation of the flushing flow rate.
6. The user should arrange suitable lighting at the area of the filter to enable good visibility and safe maintenance.
7. The user should arrange suitable platforms and safety barriers to enable easy access to the filter without climbing on pipes and other equipment.

IMPORTANT !!

- ◆ Prevent static back-pressure or reverse flow through the filter.
- ◆ Install a manual or a hydraulic valve downstream of the filter.

Electric wiring

1. **Install** the control board in a dry and protected place (It is possible to order a special control board for severe out-door installation).
For single phase or DC power supply, please refer to the electrical drawing inside the control board.
2. **Power connection to the control board:**
 - a. Connect a three-phase power source through a semi-automatic switch, or 16 Amp. fuse to the L1 L2 L3 connectors at the terminal strip in the control board.
 - b. Ground the control board.
3. **Power connection to the motor:**

Connect the drive unit to the control panel by means of a 4 x 2.5 mm (12 or 14 AWG) wire in flex-conduct. Use a long enough cable to allow removal of the drive unit and placing it near the filter for maintenance, without having to disconnect it from the cable. (It is recommended that this installation meets or exceeds local or national electrical codes, this is a "high" voltage connection).
4. **Control wiring:**

Connect between the control junction box and the control board by means of 6 x 1.5 mm² (16 AWG) wire in flex-conduct. The numbers on the terminals in the board and in the junction box are identical.

Start-up and first operation

1. **Make sure all the electric wiring is correct, according to the enclosed drawings.**
2. Switch the control & 24V circuit breakers and the motor protector to ON. The motor will start operating *.
1. The suction scanner shaft should turn clockwise and move towards the filter housing until it reaches limit switch "A". If the motor rotates in the opposite direction, disconnect the electricity immediately and change the direction of the motor rotation by changing between two phases.
2. The motor must stop when the limit switch plate reaches limit switch "A" and causes it to operate.
3. Operate a "dry" flushing cycle by pressing on the "TEST" push button. Make sure all flushing stages occur as described in the filter description chapter of this manual.
4. Open the inlet valve to the filter, while the outlet valve remains closed or with an open by-pass valve (This will keep the flow in the filter at a minimum), and operate a flushing cycle.
5. Make sure the exhaust valve opens and all stages of the flushing cycle are carried out. Attend to leakage, if any.
6. Close the 1/4" valve at the low pressure point of the pressure differential switch for 5 seconds. The PDS hand will move to the red area and the filter will start the flushing process. Open the 1/4" valve.
1. Gradually open the outlet valve and/or close the by-pass valve. Operate the filter at the designed hydraulic conditions.
2. Set the timer for 6-8 hours.
7. Check and re-tight all bolts after the first week of operation.

* When using Control board type "C" (Relay type) it is necessary to press the "Test" push button in order to start the motor operation for the first time.

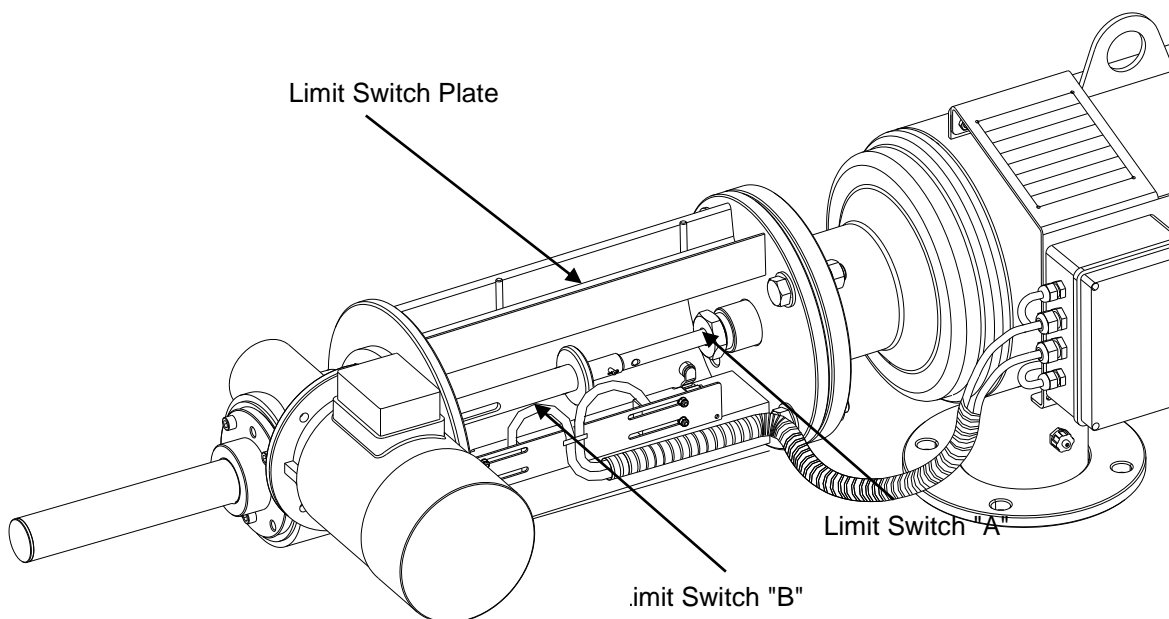

MAINTENANCE

General inspection

In order to check the proper operation of the filter, close the low-pressure 1/4" valve to the pressure differential switch for a period of 5 seconds. This will initiate the self-cleaning cycle: Check that the exhaust valve opens, that the scanner moves forwards, and when it reaches the limit switch - verify that the exhaust valve closes.

Weekly maintenance:

1. Check that the filter operates properly, following a general inspection.
2. Clean the 3/4" filter (close the 3/4" valve and operate a flushing cycle in order to release pressure and then open the bowl).
3. Check that there is grease on the drive shaft, and drive bushing. Add grease if necessary.
4. Take care of any leakage from the scanner shaft. If necessary, replace the sealing nut internal O-Ring.

Changing the sealing nut internal O-ring:

1. Close the inlet valve to the filter and release the pressure.
2. Remove the cover (29) from the drive shaft housing (4) by unscrewing the wing nuts (29).
3. If the Suction Scanner is in the outer position, operate a flushing cycle and bring it to the inner position.
4. Remove the Split pin (10) and pull out the connecting pin (9).
5. Operate a flushing cycle.
6. Stop the motor operation when the drive shaft reaches half way of its movement. The drive shaft is now separated from the Suction Scanner.
7. Unscrew the sealing nut (7.5).
8. Remove the used internal O-ring and clean the O-ring seat.
9. Insert a new O-ring (16 p.24).
10. Apply some grease on the external O-ring and on the shaft.
11. Tighten the sealing nut (14 p.24).
12. Re-connect the drive shaft to the suction scanner shaft.
13. Operate the control board and open the filter inlet valve.

Maintenance prior to long term cessation of filter operation:

The following must be done if the filter will not be in operation for more than a month.

1. Operate a flushing cycle (If possible, with a closed downstream valve).
2. Disconnect the power supply to the control board.
3. Release pressure from the filter.
4. Grease the drive shaft and the drive bushing.
5. Clean the 3/4" control filter.
6. Clean the coarse screen.

Maintenance prior to re-operation:

1. Connect the control board to the power supply.
2. Check proper operation of the filter.
3. Grease the drive shaft and the drive bushing.
4. If necessary, change the Sealing nut internal O-Ring.

IMPORTANT!!

THE DRIVE SHAFT MUST BE LUBRICATED WITH HEAVY-DUTY, WATER RESISTANT GREASE THAT WILL NOT OXIDIZE. (SHELL, DARINA EP-2 OR SIMILAR).

Cleaning the coarse screen:

Close the filter inlet valve.

2. Release pressure from the filter by operating a flushing cycle.
3. Remove the filter lid (17), pull out the flushing chamber (15) with its seal.
4. Pull out the coarse screen (11) and clean it.
5. Insert the coarse screen (11) in its position, so that it rests on its supports.
6. Insert the flushing chamber into the lid (15+17), Make sure the seal is on top of the chamber centering ring with its opening facing the inner side of the filter housing. The insertion should be done at a slight angle and in a circular motion.
7. Close and tighten the filter lid.

DISMANTLING AND ASSEMBLING THE FILTER COMPONENTS

Prior to opening the filter perform a flush cycle by pressing the "TEST" push button.

Dismantling the screens:

1. Close the filter inlet and outlet valves and release the pressure by operating a flushing cycle, Disconnect power supply from the control board.
2. Release the lid bolts (19,20) from their nuts and remove the lid (17).
3. Pull out the flushing chamber (15) with its seal (13).
4. Pull out the coarse screen (11) and clean it if necessary.
5. Pull out the upper cylinder seal (12).
6. Pull the screen (14) out of the filter housing.
7. If required, remove the lower screen seal (12).

Assembly:

1. Verify presence of the lower screen seal (12) on the screen edges.
2. Insert the screen into the filter housing (1) while the support legs point upwards. After pushing the screen all the way in, rotate the screen so that the legs will support it and lead it to its position. Turn the screen round until the locking pin (on the inner side of the housing wall) is situated in its slot on the centering ring (14).
3. Insert the cylinder seal (12), so that its open side faces the direction of the filter lid.
4. Clean and apply some grease on the suction scanner pipe and on the O-ring (12) of the suction scanner bearing located in the flushing chamber.
5. Insert the coarse screen (11) in its position, so that it rests on its supports.
6. Insert the flushing chamber (15), make sure the seal is on top of the chamber centering ring with its opening facing the inner side of the filter housing. The installation should be done at a slight angle and in circular motion.
7. Assemble the lid on the filter housing. Tighten the bolts (19,20) in a controlled and balanced method.
8. Open the filter inlet and outlet valves and operate the control board.
9. Check proper operation of the filter.

Dismantling the suction scanner:

1. Close the inlet valve to the filter, release the pressure and disconnect power supply from the control board.
2. Remove the cover (29) from the drive shaft housing (4) by unscrewing the wing nuts (23.6).
3. Remove the Split pin (10) and pull out the connecting pin (9).
4. Begin the dismantling procedure as per 1-6 in the chapter "dismantling the screens".
5. Pull the suction scanner (8) in a spiral movement out of the filter housing.

Assembly:

1. Apply some grease on the smooth side of the suction scanner shaft (2 p.22) and insert it through the filter housing.
2. Insert the suction scanner shaft (2 p.22) into the drive shaft (2 p.24). Make sure the holes in the above shafts are parallel.
3. Insert the connecting pin (9) to the parallel hole of the suction scanner shaft (2 p.24) and the drive shaft (2 p.22) and lock it with the split pin (10).
4. Continue to assemble the parts as per 1-9 in the chapter "Assembling the screens".

Dismantling the drive shaft housing:

1. Close the inlet valve to the filter, release the pressure and disconnect power supply from the control board.
2. Dismantle the suction scanner and screens as described previously.
3. Remove the limit switch sling (6 p.24) from the drive shaft housing by unscrewing the bolts. Carefully put the limit switch sling near the filter to avoid any damage to the electrical wires.
4. Remove the drive unit (22) from the drive shaft housing (4 p.24) by unscrewing the nuts from the bolts. By doing so the drive shaft key (21) will be pulled out.
5. Dismantle the drive shaft housing (4) from the housing flange by unscrewing the bolts.

Assembly:

1. Verify that the O-ring (3) is clean and in its place.
2. Tighten the flange of the drive shaft housing to the filter with bolts.
3. Insert the suction scanner, the fine screen and the coarse screen as described previously.
4. Connect the drive shaft to the scanner shaft using the connecting pin and split pin.
5. Make sure the drive shaft key (21) is fitted properly in the gear box. Thread the drive shaft through the drive unit and make sure that the drive shaft groove is adjusted in accordance with the drive shaft key.
6. Connect the drive unit (22) to the drive shaft housing (4) with the bolts and tighten them.
7. Assemble the limit switch sling (6 p.24) in its place. Make sure that the Limit Switch Plates is in the middle of the scanner travel.
8. Operate the control board and make sure the filter is operating properly.
9. Open the inlet and outlet valves and recheck filter operation.

PARTS LIST – Standard SAF-1500

No.	DESCRIPTION	Qty.
1	Housing 3" SAF-1500	1
2	Slotted Pin 10x30 DIN1481	1
3	O-Ring Seal P2-433 (Drive Unit Adaptor EBS H-SAF) NBR N/F	1
4	Drive Shaft Assembly SAF-1500/3000	1
5	Bolt M16X60 Z.Plated	4
6	Flat Washer M16 Z.Plated	8
7	Hex Nut M16 Z.Plated	4
8	Suction Scanner Assembly SAF-1500	1
9	Connecting Pin (SAF-1500,3000, 4500)	1
10	Split Pin 1.6X12 DIN94 S/ST316	1
11	SAF-1500/3000 Coarse Screen	1
12	Hydraulic Seal AM-02	1
13	Flushing Chamber Seal AM-01	1
14	Weavewire Screen For SAF 3000	1
15	Flushing Chamber (SAF-1500)	1
16	Hydraulic Seal AM-07 (Polyester Lid)	1
17	Lid Polyester SAF-1500,3000	1
18	Hex Bolt Partial Thrd M20x130Z.Plated	4
19	Hex Nut M20 Z.Plated	4
20	Flat Washer M20 Z.Plated	4
21	Drive Shaft Key (SAF)	1
22	Drive Unit 440AC3PH 0.18KW.RMI50 1/28 63 B5	1
23	Hex Bolt Full Thread M8X40 Z.Plated	4
24	Hex Nut M8 Z.Plated	4
25	Flat Washer M8 Z.Plated	8
26	Spring Washer M8 Z.Plated	4
27	Drive Shaft Cover (PVC) SAF	1
28	Socket Head Cap Screw M8x20 S/St304 DIN912	2
29	Drive Shaft Housing Cover SAF 1500	1
30	Insrtumentation Combined Bracket SAF	1
31	Aluminum Amiad Nameplate, CE, En	1
32	Rivet Blind 3x6 DIN7337 S/ST316	4
33	Manometer Valve 1/4" W/ Drain	1
34	Connector 5/16"x1/4"	2
35	L-Connector 5/16"X1/4"	3
36	Electrical Junction Box (SAF)	1
37	Flat Washer M5 DIN125 304	4
38	Hex Nut M5 304 DIN934	4
39	Phillips Pan Machine Screw M5x16 S/St304 DIN7985	4
40	Presostat SUB-AS. Midwest W/O Fitting	1
41	L-Connector 5/16"X1/8"	2
42	Connector 5/16"x1/8"	1
43	Flat Washer M6 DIN125 S/ST316	4
44	Spring Washer M6 DIN127 S/ST316	2
45	Hex Nut M6 DIN934	2
46	Hex Bolt Full Thread M6x20 S/St304 DIN933	2

No.	DESCRIPTION	Qty.
47	Ball Valve 3/4" M/F (BRASS)	1
48	L-Connector 3/4" F/M Galvanized	1
49	3/4" BSPT AC BLACK SCREEN 200 M	1
50	Raccord Nipple 1/4" for 3/4" Filter	1
51	Raccord Nut 3/4" for 3/4" Filter	1
52	O-Ring Seal P2-112 NBR	1
53	Hydraulic Valve	1
54	Pressure Check Point Connector 1/4"X1/4"	1
55	Solenoid Valve	1
56	Control Tube 5/16" Nylon Air Brake	1.6m

PARTS DRAWING - Standard SAF-1500
Section 1: Page 1

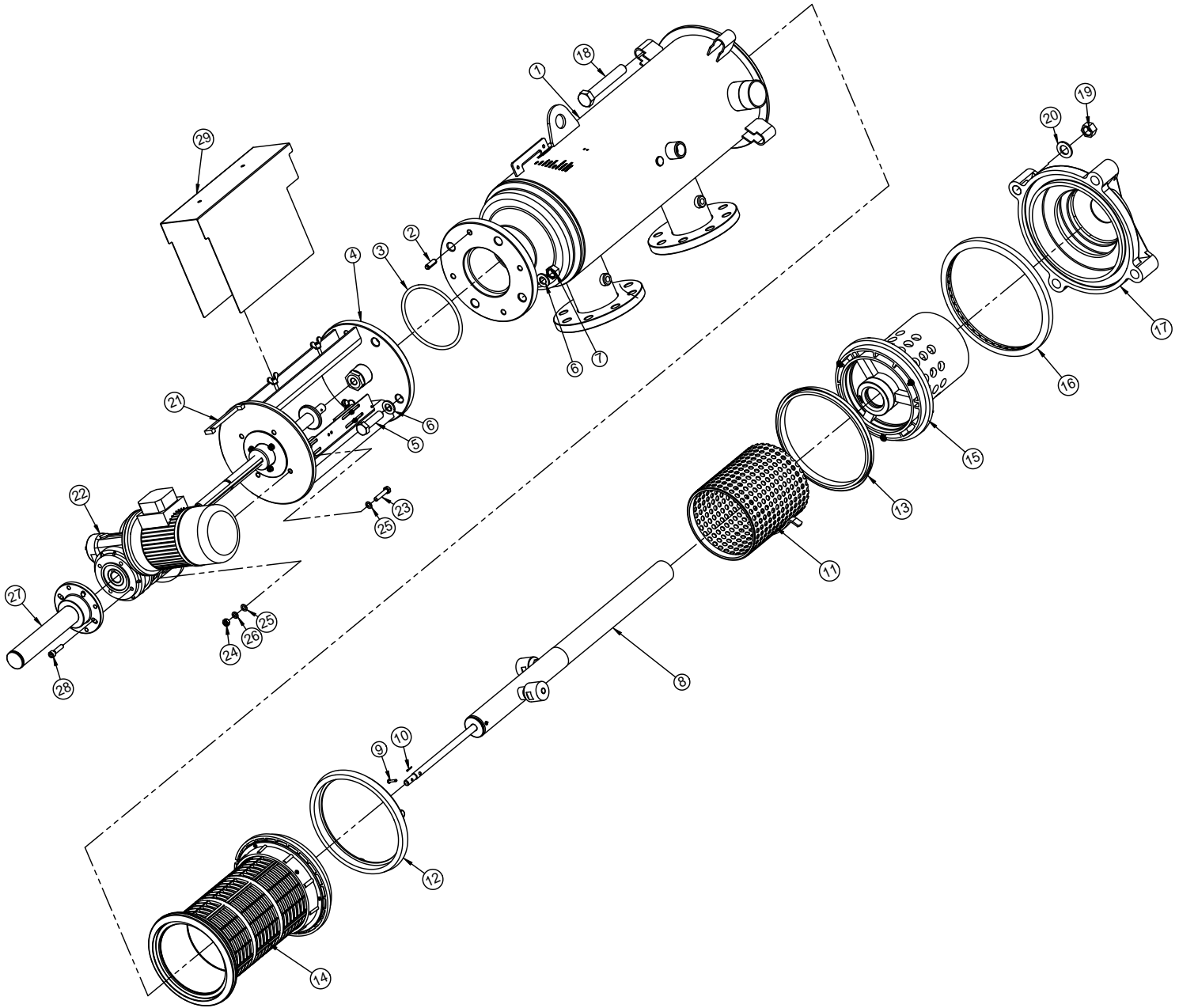

PARTS DRAWING - Standard SAF-1500
Section 1: Page 2

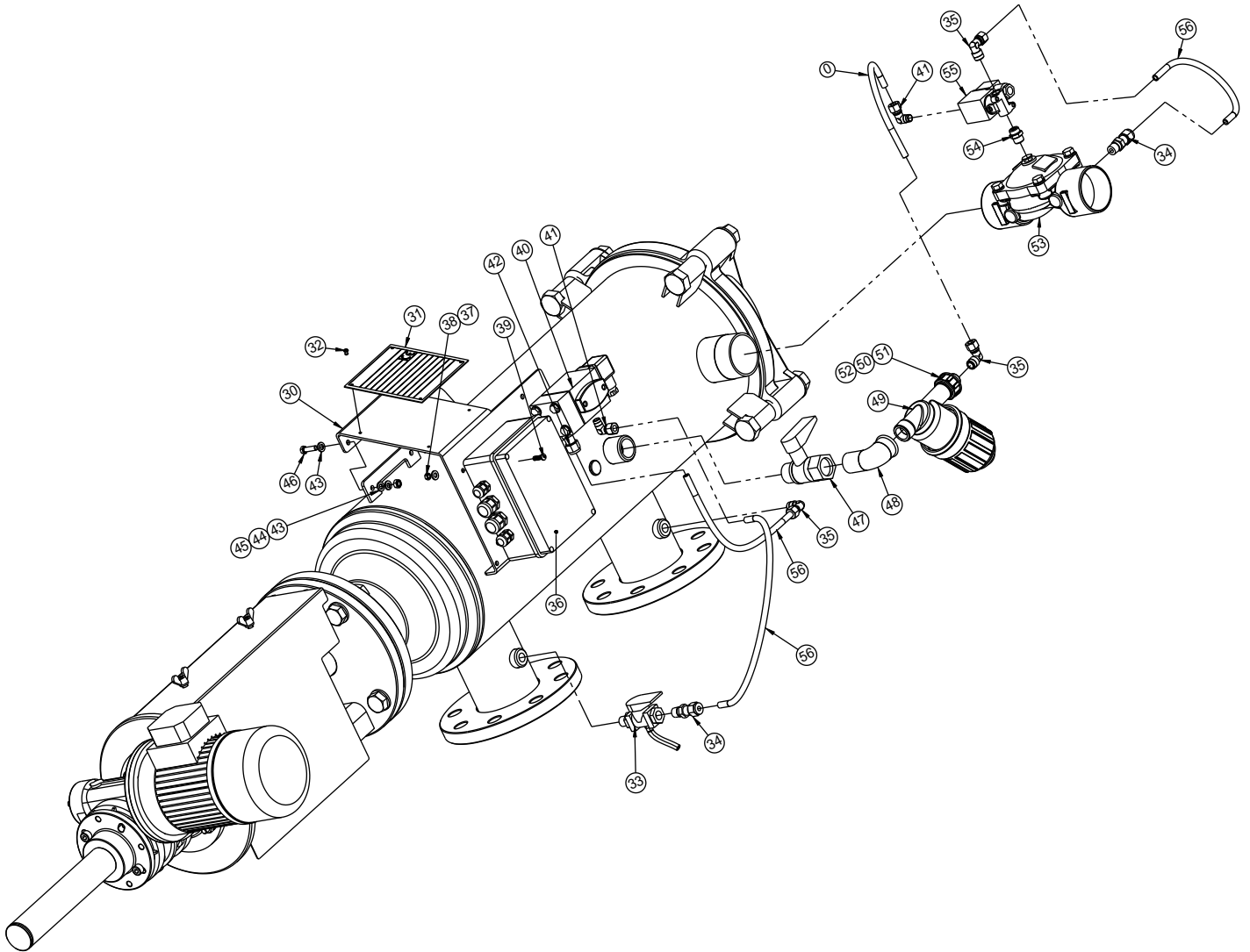

PARTS SCHEDULE & DRAWING – Standard SAF-1500 Filter Section 2: Drive Shaft Housing

NO.	DESCRIPTION	QTY.
1	Drive Shaft Housing SAF-1500/3000 PKPK-3002	1
2	Drive Shaft (SAF-1500,3000,4500)	1
3	Drive Bushing (SAF)	1
4	Limit Switch Plate (SAF) HD	1
5	EXT RETAINING RING 17MM S/ST304 DIN471	1
6	HD Limit Switch Sling (SAF)	1
7	Limit Switch NC (EBS,SAF) FA 4131-2DN	2
8	Phillips Pan Machine Screw M4x20 DIN7985	3
9	Flat Washer M4 DIN125 S/ST304	3
10	Hex Bolt Full Thread M6x35 DIN933 S/St 304	3
11	Flat Washer M6 DIN125 S/ST316	16
12	Nylon Insert Lock Nut M6 S/ST304 DIN985	3
13	Nylon Insert Lock Nut M4 S/ST304 DIN985	3
14	SAF-4500 Tightening Nut	1
15	O-Ring Seal 24x3 (Tightening Nut SAF)NBR "S"	1
16	O-Ring Seal 14x3 NBR "S"	1
17	Hex Bolt Full Thread M6x20 S/St304 DIN933	2
18	Hex Nut M6 S/ST316 DIN934	4
19	Hex Bolt Full Thrd M6x60 S/St 304 DIN933	2
20	Spring Washer M6 DIN127 S/ST316	2
21	Wing Nut M6 304 DIN315	2

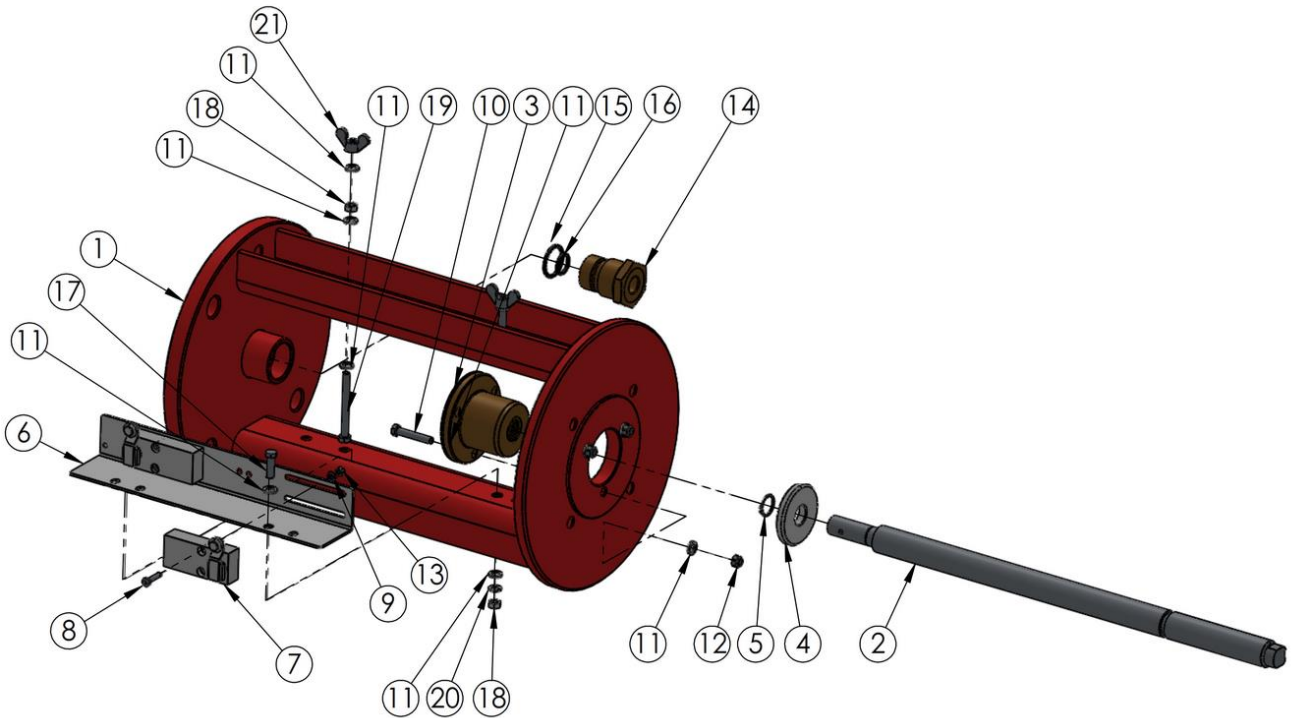

PARTS SCHEDULE & DRAWING – Standard SAF-1500 Filter Section 3: Scanner

NO.	DESCRIPTION	QTY.
1	SUCTION SCANNER SAF-1500 SS316L F/SCANNER DW	1
2	SUCTION SCANNER SHAFT SAF-1500 SS316 DW	1
3	PIN FOR SHAFT (SAF-1500) 35X5 S/ST	1
4	PLUG 8MM SAF POM F/SCANNER	1
5	NOZZLE SAF-1500 POM SCANNER	2

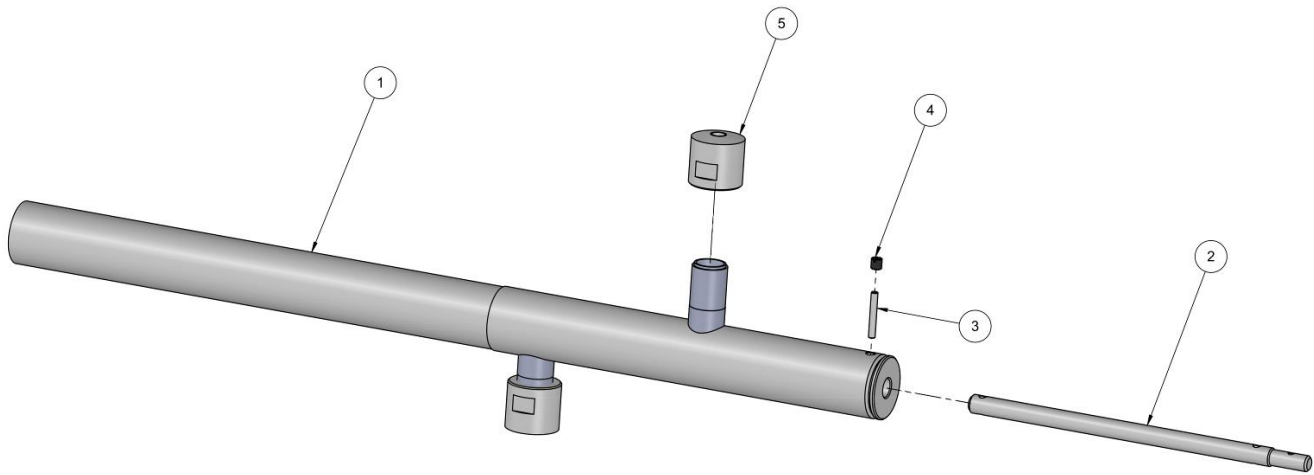

PARTS SCHEDULE & DRAWING - Standard SAF-1500 Filter Section 3: SLN Scanner

NO.	DESCRIPTION	QTY.
1	SLN SUC Scan Assy IMPR SAF-1500 Machined	1
2	Suction Scanner Shaft (SAF-1500)	1
3	SLN Body SAF-3000/1500	2
4	Spring Loaded Nozzle Seal - SAF (Blue)	4
5	SLN Tightening Nut SAF-4500/3000	2
6	SLN Cap SAF-3000/45000	2
7	SLN Spring Seat SAF-3000/4500	2
8	Spring Loaded Nozz. Spring SAF-3000/4500	2
9	O-RING Seal 2-016 NBR	2
10	Plug Threaded M8 for SAF-6000 PRO	1
11	Connecting pin 35x5 (shaft to scanner)	1

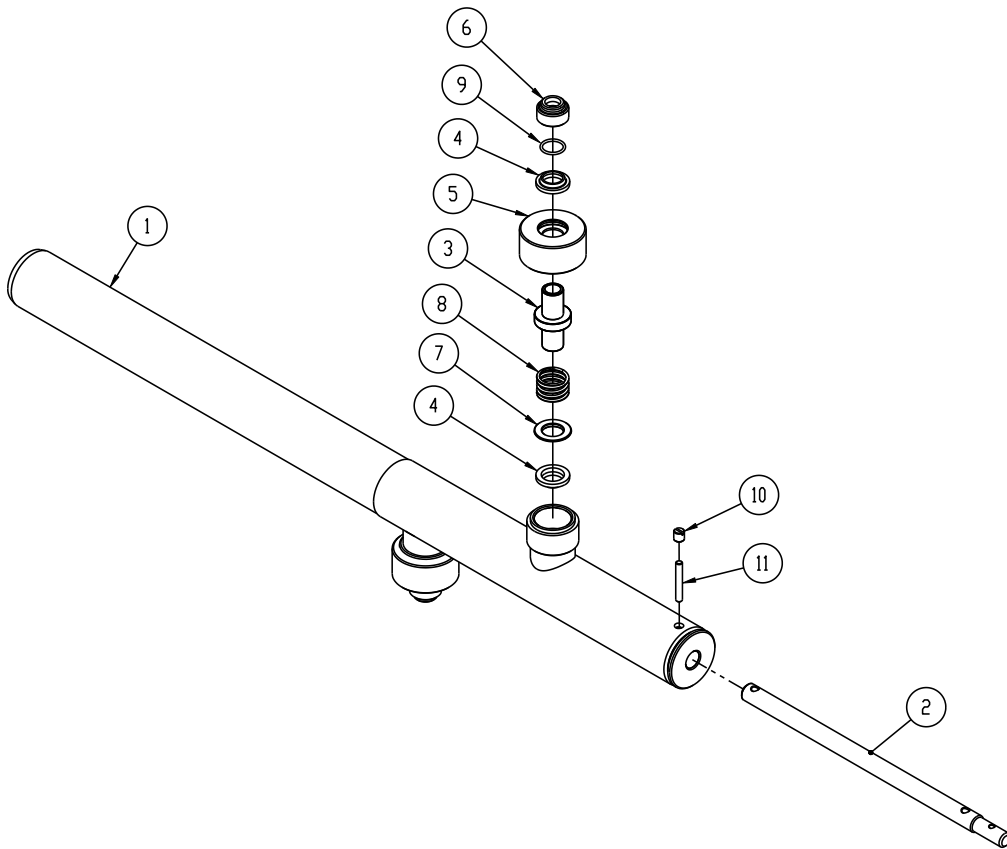

AMIAD LIMITED WARRANTY

1. This certificate applies to Amiad Water Systems Ltd. ("**Amiad**") products purchased by you (the "**Buyer**") from Amiad unless specifically agreed otherwise in writing by Amiad. This Warranty extends only to the original purchaser, and is not transferable to anyone who subsequently purchases, leases, or otherwise obtains the product from the original purchaser.
2. Amiad hereby warrants that the products are and will be free from defects in material and workmanship under normal use and service. Amiad warrants that it will correct manufacturing defects in the products, in accordance with the conditions set out in this Warranty.
3. This Warranty is enforceable for a period of 12 months after the date upon which the products were delivered (the "**Warranty Period**").
4. In the event that during the Warranty Period the Buyer discovers a defect in material and/or workmanship in any product or part (the "**Defective Product**"), it shall submit a written complaint to Amiad using Amiad's standard Buyer Complaint Form. For the receipt of the Buyer Complaint Form, the submission of the complaint or any questions please contact your service representative.
5. Upon written demand by Amiad the Buyer shall return the Defective Product - or a sample thereof - to Amiad, at Amiad's cost. If the Buyer ships any such Defective Product, Amiad suggests the Buyer package it securely and insure it for value, as Amiad assumes no liability for any loss or damage occurring during shipment. Provided however that in the event Amiad determines that this Warranty does not apply to such product, Buyer shall promptly reimburse Amiad for such cost (including freight and customs). Any returned product or part must be accompanied by the Warranty certificate and the purchase invoice. It is clarified that the Buyer may not return the Defective Product unless such return was coordinated and approved by Amiad in advance.
6. Amiad's obligation under this Warranty shall be limited to, at Amiad's option, the repair or exchange, free of charge, of the product or any part which may prove defective under normal use and service during the Warranty Period. The provision of a repair or replacement of a product during the Warranty Period will result in an extension of the Warranty Period by an additional period of 12 months, provided that the total accumulated Warranty Period shall in any event be no more than 18 months from the date upon which the products were delivered.
7. This Warranty is valid on the condition that the products are installed according to Amiad's instructions as expressed in Amiad's instruction manuals and according to the technical limitations as stipulated in Amiad's literature or as stated by a representative of Amiad.
8. This Warranty will not apply to damaged or defective products resulting from or related to:
 - (i) Fire, flood, power surges or failures or any other catastrophe and/or unforeseen occurrence, such as but not limited to those for which the Buyer is customarily insured for, or any force majeure events;
 - (ii) Fault, abuse or negligence of the Buyer;
 - (iii) Intake water not meeting the agreed standards, as set forth in a written document, approved by Amiad, or improper storage;
 - (iv) Improper or unauthorized use of the product or related parts by the Buyer, including Buyer's failure to operate the product in conformity with the recommendations and instructions of Amiad, as set forth in Amiad's manuals and other written materials, the operation of the product other than by a trained and qualified operator, or improper installation of the product by a third party not authorized by Amiad;
 - (v) Performance by the Buyer of maintenance or operation other than in conformity with the recommendations and instructions of Amiad, or other than in accordance with procedures defined in the literature supplied for products (including the timely replacement of requisite parts), and for services provided other than by a trained and qualified advanced operator; or
 - (vi) Any alteration, modification, foreign attachment to or repair of the products, other than by Amiad or its authorized technical representatives.
9. In no event shall Amiad be liable to the Buyer or any third party for any damages to property, or for any intangible or economic loss, including loss of profits, loss of customers or damage to reputation, for any damages, including indirect, special, consequential damages, or punitive damage arising out of or in connection with this Warranty, or arising out of or in connection with the product's performance or failure to perform, even if it has been advised of the possibility of such damages.
10. Amiad will be excused for failure to perform or for delay in performance hereunder if such failure or delay is due to causes beyond its reasonable control or force majeure preventing or hindering performance.
11. This Warranty set forth herein is the only contractual warranty given by Amiad and is provided in lieu of any other warranties created by any documentation, packaging or otherwise.
12. Amiad makes no warranty whatsoever in respect to accessories or parts not supplied by Amiad. In the event that Amiad is required to correct a Defective Product or product not covered by this Warranty, it will do so solely in consideration for additional fees.
13. The parties will actively endeavor to amicably settle any dispute arising between them. In the event that the parties are unable to reach an equitable settlement of such dispute, any claim or lawsuit related to the Warranty, its validity execution, its performance be brought before only the courts of Tel-Aviv, Israel. Israeli law will govern the Warranty, to the exclusion of any conflict of law rules.

Алматы (7273)495-231
Ангарск (3955)60-70-56
Архангельск (8182)63-90-72
Астрахань (8512)99-46-04
Барнаул (3852)73-04-60
Белгород (4722)40-23-64
Благовещенск (4162)22-76-07
Брянск (4832)59-03-52
Владивосток (423)249-28-31
Владикавказ (8672)28-90-48
Владимир (4922)49-43-18
Волгоград (844)278-03-48
Вологда (8172)26-41-59
Воронеж (473)204-51-73
Екатеринбург (343)384-55-89

Иваново (4932)77-34-06
Ижевск (3412)26-03-58
Иркутск (395)279-98-46
Казань (843)206-01-48
Калининград (4012)72-03-81
Калуга (4842)92-23-67
Кемерово (3842)65-04-62
Киров (8332)68-02-04
Коломна (4966)23-41-49
Кострома (4942)77-07-48
Краснодар (861)203-40-90
Красноярск (391)204-63-61
Курск (4712)77-13-04
Курган (3522)50-90-47
Липецк (4742)52-20-81

Магнитогорск (3519)55-03-13
Москва (495)268-04-70
Мурманск (8152)59-64-93
Набережные Челны (8552)20-53-41
Нижний Новгород (831)429-08-12
Новокузнецк (3843)20-46-81
Ноябрьск (3496)41-32-12
Новосибирск (383)227-86-73
Омск (3812)21-46-40
Орел (4862)44-53-42
Оренбург (3532)37-68-04
Пенза (8412)22-31-16
Петрозаводск (8142)55-98-37
Псков (8112)59-10-37
Пермь (342)205-81-47

Ростов-на-Дону (863)308-18-15
Рязань (4912)46-61-64
Самара (846)206-03-16
Санкт-Петербург (812)309-46-40
Саратов (845)249-38-78
Севастополь (8692)22-31-93
Саранск (8342)22-96-24
Симферополь (3652)67-13-56
Смоленск (4812)29-41-54
Сочи (862)225-72-31
Ставрополь (8652)20-65-13
Сургут (3462)77-98-35
Сыктывкар (8212)25-95-17
Тамбов (4752)50-40-97
Тверь (4822)63-31-35

Тольятти (8482)63-91-07
Томск (3822)98-41-53
Тула (4872)33-79-87
Тюмень (3452)66-21-18
Ульяновск (8422)24-23-59
Улан-Удэ (3012)59-97-51
Уфа (347)229-48-12
Хабаровск (4212)92-98-04
Чебоксары (8352)28-53-07
Челябинск (351)202-03-61
Череповец (8202)49-02-64
Чита (3022)38-34-83
Якутск (4112)23-90-97
Ярославль (4852)69-52-93

Россия +7(495)268-04-70

Казахстан +7(7172)727-132

Киргизия +996(312)96-26-47

<https://amiad.nt-rt.ru> || afv@nt-rt.ru