

Алматы (7273)495-231
Ангарск (3955)60-70-56
Архангельск (8182)63-90-72
Астрахань (8512)99-46-04
Барнаул (3852)73-04-60
Белгород (4722)40-23-64
Благовещенск (4162)22-76-07
Брянск (4832)59-03-52
Владивосток (423)249-28-31
Владикавказ (8672)28-90-48
Владимир (4922)49-43-18
Волгоград (844)278-03-48
Вологда (8172)26-41-59
Воронеж (473)204-51-73
Екатеринбург (343)384-55-89

Иваново (4932)77-34-06
Ижевск (3412)26-03-58
Иркутск (395)279-98-46
Казань (843)206-01-48
Калининград (4012)72-03-81
Калуга (4842)92-23-67
Кемерово (3842)65-04-62
Киров (8332)68-02-04
Коломна (4966)23-41-49
Кострома (4942)77-07-48
Краснодар (861)203-40-90
Красноярск (391)204-63-61
Курск (4712)77-13-04
Курган (3522)50-90-47
Липецк (4742)52-20-81

Магнитогорск (3519)55-03-13
Москва (495)268-04-70
Мурманск (8152)59-64-93
Набережные Челны (8552)20-53-41
Нижний Новгород (831)429-08-12
Новокузнецк (3843)20-46-81
Ноябрьск (3496)41-32-12
Новосибирск (383)227-86-73
Омск (3812)21-46-40
Орел (4862)44-53-42
Оренбург (3532)37-68-04
Пенза (8412)22-31-16
Петрозаводск (8142)55-98-37
Псков (8112)59-10-37
Пермь (342)205-81-47

Ростов-на-Дону (863)308-18-15
Рязань (4912)46-61-64
Самара (846)206-03-16
Санкт-Петербург (812)309-46-40
Саратов (845)249-38-78
Севастополь (8692)22-31-93
Саранск (8342)22-96-24
Симферополь (3652)67-13-56
Смоленск (4812)29-41-54
Сочи (862)225-72-31
Ставрополь (8652)20-65-13
Сургут (3462)77-98-35
Сыктывкар (8212)25-95-17
Тамбов (4752)50-40-97
Тверь (4822)63-31-35

Тольятти (8482)63-91-07
Томск (3822)98-41-53
Тула (4872)33-79-87
Тюмень (3452)66-21-18
Ульяновск (8422)24-23-59
Улан-Удэ (3012)59-97-51
Уфа (347)229-48-12
Хабаровск (4212)92-98-04
Чебоксары (8352)28-53-07
Челябинск (351)202-03-61
Череповец (8202)49-02-64
Чита (3022)38-34-83
Якутск (4112)23-90-97
Ярославль (4852)69-52-93

Россия +7(495)268-04-70

Казахстан +7(7172)727-132

Киргизия +996(312)96-26-47

<https://amiad.nt-rt.ru> || afv@nt-rt.ru

AMIAD Water Systems

EBS-15,000 In-Line 16" - 20"

Serial number: _____

Order number: _____

Catalog number: _____

Filtration degree: _____

Tested by: _____

Installation, Operation and Maintenance Instructions

AMIAD WATER SYSTEMS

EBS-15,000 IN-LINE FILTER 16" – 20"



Disclaimer:

TABLE OF CONTENTS

SPECIFICATIONS.....	4
GENERAL.....	4
FLUSH DATA.....	4
CONTROL AND ELECTRICITY.....	4
CONSTRUCTION MATERIALS.....	4
FILTRATION DEGREES AVAILABLE.....	4
GENERAL SAFETY INSTRUCTIONS	5
INSTALLATION	5
COMMISSIONING.....	6
OPERATION AND CONTROL	6
MAINTENANCE.....	7
DIMENSIONAL DRAWING & RECOMMENDED INSTALLATION	8
DISMANTLING & ASSEMBLING OF FILTER COMPONENTS	15
PARTS LIST – EBS-15000, IN-LINE	18
PARTS DRAWING #1	19
PARTS DRAWING #2	20
PARTS DRAWING #3	21
AMIAD LIMITED WARRANTY	22

With any inquiry please quote Filter Serial Number, located on the filter housing.

SPECIFICATIONS

General

Maximum flow rate	1800m ³ /h; 7925USgpm	Consult manufacturer for optimum flow depending on filtration degree & water quality.
Min. working pressure	2bar; 29psi	Or lower if pressure is increased for flushing
Max. working pressure	10bar; 150psi	16bar (240psi) upon request
Filter area	15,000cm ² ; 2325in ²	
Inlet/Outlet diameter	400-500mm 16"-20"	Flange standards as per request.
Filter housing diameter	711mm; 28"	Epoxy-coated steel or other on request.
Max. working temperature	60°C; 140°F	
Weight (empty)*	684kg; 1508lb	
Volume*	500liter; 132USgal	

*Refers to in-line model only

Flush data

Exhaust valve	80mm; 3"	
Flushing cycle time	36 seconds	
Wasted water per cycle	500liter; 132USgal	at 2bar (30psi)
Minimum flow for flushing	50m ³ /h; 220USgpm	at 2bar (30psi)

Control and electricity

Electric motor	1/2 HP / 50 / 60 Hz, 20 / 24 Gear output R.P.M.
Rated operation voltage	3 phase, 220 - 480 V, 50 / 60 Hz
	Single phase, 110 / 220 V, 50 / 60 Hz
Control voltage	24V AC (or 24V DC upon request)
Current consumption	1.5 Amp. (with 3 phase 380V / 440V)

Construction materials

Filter housing and lid	Epoxy-coated Carbon Steel 37-2
Screen	Four-layer Weave Wire stainless steel 316L
Cleaning mechanism	Stainless Steel 316, Acetal
Exhaust valve	Epoxy-Coated Cast Iron, Natural rubber
Seals	Synthetic Rubber, Teflon
Control system	Aluminum, Brass, Stainless Steel, PVC

Filtration degrees available

micron	800	500	300	200	130	100	80	50	25	10
mm	0.8	0.5	0.3	0.2	0.13	0.1	0.08	0.05	0.02	0.01
mesh	20	30	50	75	120	155	200	300	450	600

SAFETY INSTRUCTIONS

General Safety Instructions

- Amiad filtration products always operate as components in a larger system. It is essential for the system designers, installers and operators to comply with all the relevant safety standards.
- Prior to installation, operation, maintenance or any other type of action carried out on the filter, read carefully the safety, installation and operation instructions.
- During installation, operation or maintenance of the filter all conventional safety instructions should be observed in order to avoid danger to the workers, the public or to property in the vicinity.
- Please note: The filter enters into a flushing mode automatically, without prior warning.
- No change or modification to the equipment is permitted without a written notification given in advance by the manufacturer or by its representative, on the manufacturer's behalf.
- Always observe standard safety instructions and good engineering practices whilst working in the filter's vicinity.
- Use the filter only for its intended use as designed by Amiad, any misuse of the filter may lead to undesired damage and may affect your warranty coverage. Please consult with Amiad prior to any non-regular use of this equipment.

Installation

General

- Install the filter according to the detailed Installation Instructions provided with the filter by the manufacturer and according to the description given in this manual.
- Make sure to leave enough clearance so as to enable easy access for future treatments and safe maintenance operations.
- The user should arrange suitable lighting at the area of the filter to enable good visibility and safe maintenance.
- The user should arrange suitable platforms, ladders and safety barriers to enable easy and safe access to the filter without climbing on pipes and other equipment. The user should verify that any platform, barrier, ladder or other such equipment is built, installed and used in accordance with the relevant local authorized standards.
- Check and re-tighten all bolts during commissioning and after the first week of operation.
- Use only appropriate standard tools and equipment operated by qualified operators when installing, operating and maintaining the filter.
- When installation is required in hazardous environment sites, underground or high above ground, make sure that the site design and the auxiliary equipment are appropriate and that installation procedures are carried out in accordance with the relevant standards and regulations.
- Ensure walking areas about the installation are slip free when wet.

Shipment and transporting

- Shipping and transporting the filter must be done in a safe and stable manner and in accordance with the relevant standards and regulations.
- For shipping, lifting and positioning the filter, use only approved lifting equipment and authorized employees and contractors.

Electricity

- Electric wiring should be performed by an authorized electrician only, using standardized and approved components.
- Install a **lockable** main power cut-off switch close to the control panel.
- If due to site constraints, the control panel is installed without a clear line-of sight of the filter, an additional **lockable** power disconnect cut-off switch should be installed near each filter unit.
- Installation of the filter should be performed so as to avoid direct water splashing on the electrical components or on the control panel.

Pneumatics

- Install a **lockable** main cut-off switch, **featured with a pressure release mechanism**, on the compressed air supply line close to the control panel.
- If the control panel is installed far away and there is no eye contact with the filter, a **lockable** compressed air cut-off switch, **featured with a pressure release mechanism**, should be installed near each filter unit.
- The user should make sure that the compressed air supplied to the filter never exceeds the maximum designated pressure for this filter. An air-pressure reduction valve should be installed on the compressed air supply line upstream of the filter's pneumatic inlet port.

Hydraulics

- Extra safety devices should be installed on hot water applications to avoid skin burn danger.
- The user should install a manual Water Cut-off Valve next to the filter's inlet port.
- In cases where the downstream piping network downstream of the filter is pressurized an additional manual Water Cut-off Valve should be installed next to the filter outlet port.
- The user should make sure that the system includes a Pressure Release / Drainage Valve to enable release of residual pressure prior to any maintenance procedure performed on the filter.
- The user should make sure that the filter is never exposed to water pressure exceeding the maximum designated pressure for this filter, if needed a Pressure Reduction Valve should be installed upstream of the filter's water inlet port.
- Please note that the maximum working pressure indicated at the filter's specifications table includes the pressure caused by fluid hammer and pressure surge effects.

Civil Engineering

- Make sure that the filter installation is done by Amiad qualified technicians.
- Make sure that any civil engineering work at the installation site such as construction, lifting, welding, etc. is done by qualified workers / technicians / contractors and in accordance with the relevant local standards.
- While using lifting equipment, make sure that the filter or the lifted part is chained securely and in a safe manner.
- Do not leave lifted equipment if there is no necessity. Avoid working below lifted equipment.
- Wear a safety helmet while using lifting equipment.
- Make sure that the flooring is sloped for drainage and to avoid accumulation of liquids.

Commissioning

- Read carefully the Commissioning and the First Start-up Operation instructions prior to any attempt to operate the filter.
- In order to achieve maximum performance and smooth operation of the filter it is crucial to perform the Startup and First Operation procedures exactly as described in this manual.
- Commissioning the filter should be done by an authorized Amiad technician, do not attempt to commission the filter unaccompanied since this may lead to undesired damage and may affect your warranty coverage.

Operation and Control

- Do not operate the filter before reading carefully and being familiar with its operation instructions.
- Observe the safety stickers on the filter and never perform any operation contradicting the instructions given.
- Never operate or use the filter for purposes other than its original design and operational envelope.

Maintenance

Before any maintenance or non-regular operation please read the following:

- Servicing the filter should be done only by technicians authorized by Amiad.
- Disconnect the filter from the power supply and lock the Main Power Switch.
- Disconnect the compressed air supply, release the residual pressure and lock the Pneumatics Main Valve.
- Disconnect the filter from the water system by closing and securing the Manual Inlet Valve. In cases where the downstream piping network is pressurized, close and secure the Manual Outlet Valve also.
- Release the residual water pressure by opening the Pressure Release / Drainage Valve.
- Empty the filter by opening the Drainage Valve.
- In hot water systems wait till the filter components cool off to a safe temperature.
- Place warning signs around the work area as required by the local standards and procedures.
- Inspect the filter's safety stickers and replace any damaged or faded sticker.

Mechanical

- When working on the filter use only appropriate standard tools.
- Always open and close valves slowly and gradually.
- Remove grease and fat material residues in order to avoid slipping.
- Before disconnecting the filter from the water supply, electricity and pneumatics and before releasing the filter's residual pressure do NOT:
 - loosen or unscrew bolts
 - remove any protection cover
 - open any service port flange
- Avoid splashing and water leakage so as to minimize slippage, electrification or damage to the equipment, caused by moisture.
- While using lifting equipment, make sure that the filter or the lifted part is chained securely and in a safe manner.
- Do not leave lifted equipment if there is no necessity. Avoid working below lifted equipment.
- Wear a safety helmet, goggles, gloves, and any other personal safety equipment required by the local standards and regulations.
- Human entry into a filter must be done in accordance with the relevant local safety instructions, standards and regulations for working in hazardous environment.
- Manual cleaning of filter media using high water pressure or steam should be performed in accordance with the cleaning system instructions, the local standards and regulations and without endangering the operator or the vicinity
- Manual cleaning of filter element using acid or other chemical agents should be performed in accordance with the relevant material safety instructions, the local standards and regulations and without endangering the operator or his vicinity.

Before returning to regular operation

- Re-assemble any protection covers or protection mechanisms removed during service or maintenance operations.
- Make sure that all the tools, ladders, lifting devices, etc. used during the maintenance procedures are taken away from the filter area and stored
- In order to return the filter to regular operation, follow the First Start-up Operation instructions as detailed in your user manual.
- For filters used in potable water systems it is required to disinfect the filter according to the local water authority standards and regulations before putting it back to service.

DIMENSIONAL DRAWING & RECOMMENDED INSTALLATION

This is a conceptual installation drawing. Note that piping is not included.

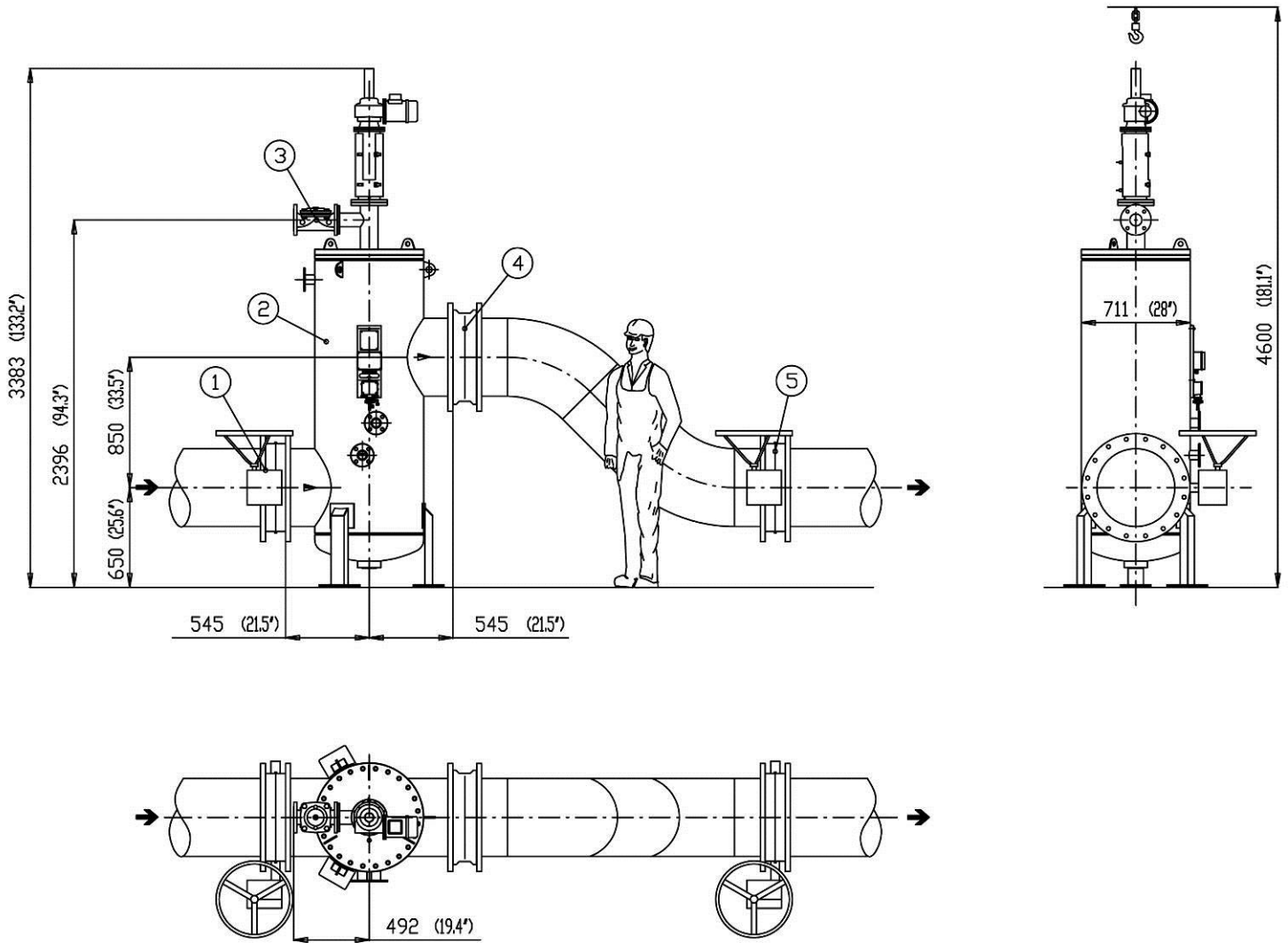

Key:

1. 20" Inlet Butterfly Valve
2. 20" EBS-15000 In-Line Filter
3. 3" Exhaust Valve
4. 20" Non-Return Valve
5. 20" Outlet Butterfly Valve

DESCRIPTION OF FILTER OPERATION

Filtering process:

The EBS is a sophisticated yet easy-to-operate automatic filter, with a self-cleaning mechanism driven by an electric motor. The EBS is designed to work with various types of screens in filtration degrees from 500 to 10 micron, and is available in 8", 10", 12" and 14" inlet/outlet diameter.

The water enters through the inlet pipe into the fine screen from inside out. The "filtration cake" accumulates on the fine screen surface and causes head loss to develop.

Self-cleaning process:

The EBS will start the self-cleaning process when the pressure differential across the screen reaches a pre-set value or a predetermined lapse of time.

Cleaning of the filter element is carried out by the suction scanner, which rotates in a spiral movement while removing the filtration cake from the screen and expels it out through the exhaust valve.

The scanner rotation is operated by a 2-way (fwd/rev) drive unit which is attached to the scanner by a threaded shaft, providing the linear movement.

The exhaust valve is activated for the duration of the cleaning cycle by a 3-way solenoid. During the self-cleaning process, which takes approximately 35 seconds, filtered water continues to flow out of the filter.

Different modes of filtration:

The filtration system may be found in one of the following modes:

1. Filtering mode: This is the normal function condition. Flushing is not occurring and the power light on the control board is lit.
2. Flushing mode: A mode in which the flushing process is in progress. The motor and the exhaust valve are operating according to the program.
3. Continuous flushing mode: It is possible to activate the self-cleaning mechanism continuously by changing the operation mode on the HMI.
4. Malfunction mode: During malfunction mode the self-cleaning operation is stopped, the malfunction light on the control board is turned on and an external output is activated. In case that there is HMI, the relevant fault error will be displayed.

The filtration system may enter a malfunction mode in the following cases:

- 1st. When there is a continuous signal from the pressure differential switch for duration of more than 15 minutes. This means that the self-cleaning process is not successful.
- 2nd. When the motor protector was activated, either manually or due to overload.
- 3rd. As a result of a malfunction in the limit switches.

Initiation of self-cleaning:

The filter will enter the self-cleaning process as a result of any of the following causes:

1. A signal from the Pressure Differential Switch (PDS) - The PDS which is situated on the filter body, sends an electric signal when the pressure differential across the screen reaches the pre-set value (usually 0.5 bar =7 psi). The control board registers the signal and operates the flushing process according to its program.
2. Manually pressing the "TEST" push button at the control board.
3. The TIMER installed in the control board allows operation of self-cleaning process at time intervals that can be set up, independent from the head loss factor. The timer resets after every flushing cycle.
4. A signal from continual flushing switch - This switch in the control board allows operation in continuous flushing mode; meaning, the filter is flushing itself all the time regardless of flow rate or water quality.

Stages of cleaning cycle:

Under normal operating condition the electrical control panel operates the "EBS" filter in the following manner;

1. The exhaust valve opens to atmosphere.
2. Five seconds delay.
3. The motor starts rotating the suction scanner shaft upward until it reaches the upper limit switch.
4. The exhaust valve closes.
5. Two seconds delay.
6. The motor starts rotating the suction shaft downward until it reaches the lower limit switch.

INSTALLATION

Design recommendations

1. If flow increases and pressure drops dramatically for a long period of time during network filling-up, it is recommended that a pressure sustaining valve is installed downstream of the filter. The pressure sustaining valve will ensure a controlled filling-up of the line.
2. If continual water flow is essential even during maintenance period, it is recommended that a manual or automatic by-pass is installed, and the isolating valves will be used to isolate each filter.
3. In places where there is an expected temporary worsening of water quality, it is possible to operate an emergency flushing program. In order to do so, a hydraulic controlled valve has to be installed downstream of the filter. For details, please consult the manufacturer.

Installation instructions

1. Before beginning the installation process, carefully read the safety instructions in chapter 2 of this document and make sure that all the workers at the installation site are fully aware of and comply with, these and any other local safety instructions.
2. Select a convenient location for the installation of the filter where operation and maintenance will be optimal. It is recommended that a standard and safe lifting auxiliary is available for maintenance.
3. Install the filter vertically. Please note that a minimum clearance of 300 mm (12 In.) (Not including a crane) is required in order to allow disassembly of the unit.
4. Ensure that the direction of flow is aligned with the arrows marked on the filter housing. (Flow outlet will always be from the side; flow inlet is from the bottom).
5. Installation of a mechanical non-return valve downstream of the filter is required.
6. If possible, prior to installing the filter, thoroughly flush the main line at the connection point in order to remove large objects that may damage the filter's internal mechanism.
7. Install a drainage pipe to the exhaust valve. Minimum 3" diameter for a maximum pipe length of 20 meters (60 feet), for longer drainage, 4" pipe diameter must be used for a maximum length of 40 meters (120 feet). Please note that no restriction is allowed on the drainage pipe. For special applications, please consult the manufacturer.
8. **If the system is designed to operate with working pressure higher than 4 bar (56 psi), it is recommended that a manual valve is installed on the exhaust pipe, in order to enable regulation of the flushing flow rate & pressure.**
9. The user should arrange suitable lighting in the vicinity of the filter to enable good visibility and safe maintenance.
10. The user should arrange suitable platforms and safety barriers to enable easy access to the filter without climbing on pipes and other equipment. All such equipment should comply with the safety clauses of the relevant local standards.

IMPORTANT!!

- ◆ Prevent static backpressure or reverse flow through the filter.
- ◆ Install a non-return valve at the outlet of the filter.
- ◆ Install a manual or a hydraulic valve downstream of the filter.

Electric wiring

1. All electrical works at the installation site must be done by a qualified and authorized electrician only. Make sure that this electrician is fully aware of all the relevant safety instructions.
2. Install the control board in a dry and protected place (In out-door installation sites make sure to use a special control board for out-door installation).
3. **Power connection to the control board:**
 - a. Connect a three-phase voltage source through a semi-automatic switch, or 16 Amp. fuse to the L1 L2 L3 inlet at the terminal strip in the control board.
 - b. Earth the control board.
4. **Power connection to the motor:**

Connect the drive unit to the control panel by means of a 4 x 2.5 mm (12 or 14 AWG) wire in flex-conduct. Use a long enough cable to allow the drive unit to be removed and placed near the filter for maintenance, without having to disconnect it from the cable. (It is recommended that this installation meets or exceeds local or national electrical codes, this is a "high" voltage connection).

5. **Control wiring:**

The connection between the control junction box and the control board should be by 6 x 1.5 mm² (16 AWG) wire in flex-conduct. The numbers on the terminals in the board and in the junction box are identical.

COMMISSIONING, START-UP AND FIRST OPERATION

1. Before starting-up the filter read the safety instruction as appear at chapter 2 of this document and pay special attention to the commissioning safety instructions.
2. Inspect the filter's installation and make sure that it is installed in accordance with the official installation drawings.
3. Verify (by authorized electrician only) that the electric wiring is correct and complies with the enclosed drawings. Make sure that the electrical start-up operation is done by an authorized electrician only.
4. Switch ON the control & 24V circuit breakers. Leave the motor circuit breaker protector OFF.
5. Toggle all limit switches to verify that they activate the correct inputs on the PLC according to the wiring schematic. Correct connections, if necessary, before proceeding to the next step.
6. Switch ON the motor protector circuit breaker The motor will start operating.
 - Control Board without Homing procedure: The suction scanner shaft should turn clockwise and move downward to the filter housing until it reaches the lower limit switch. If the motor rotates in the opposite direction, disconnect the electricity immediately and change the direction of the motor rotation by changing between two phases.
 - Control Board with Homing procedure: refer to the Homing section in the control boards operation manual.

The motor must stop when the limit switch plate reaches the lower limit switch and causes it to operate.

7. Operate a "dry" flushing cycle by pressing on the "TEST" push button. Make sure all flushing stages occur as described in the filter description chapter of this manual.
8. Open the inlet valve to the filter, while the outlet valve remains closed or with an open by-pass valve (This will keep the flow in the filter at a minimum), and operate a flushing cycle.

Make sure the exhaust valve opens and all stages of the flushing cycle are carried out. Attend to leakage, if any.
9. Gradually open the outlet valve and/or close the by-pass valve. Operate the filter at the designed hydraulic conditions.
10. Set the timer for 6-8 hours.
11. Check and re-tighten all bolts after the first week of operation.

MAINTENANCE

Before beginning any maintenance procedure, carefully read the safety instructions in chapter 2 of this document and make sure that all the workers at the filtration site are fully aware of and comply with, these and any other local safety instructions.

A. General inspection of the filter operation

This is the visual basic general inspection procedure of the filter for proper operation. It should be done regularly and prior to any scheduled maintenance procedure.

Press the test button, this will initiate the self-cleaning cycle; Check that the exhaust valve opens, that the scanner moves upwards, and when it reaches the top limit switch - verify that the exhaust valve closes.

B. Weekly maintenance

Visual Check:

1. Check that the filter operates properly by following the General Inspection of the Filter Operation as described above.
2. Visually check that there is grease on the drive shaft, and drive bushing.
3. Visually check the suction scanner for any leakage.
4. Visually check the filter housing, the valves and the check-valves for leakage.
5. Check the filter for loosen bolts.

If Necessary:

1. Disconnect and lock the filter's power supply.
2. Disconnect and lock the filter's compressed air supply.
3. Disconnect the filter from the water supply and drain the filter housing.
4. If it is necessary add grease to the filter's suction scanner shaft.
5. Take care of any leakage from the scanner shaft. If necessary, replace the Sealing flange Internal O-Ring (5 on page 23) as described at the following list:
6. Reconnect the filter carefully and safely to its water, air and power supply.
7. Perform a General Inspection of the Filter Operation as described above.

Changing the sealing flange internal O-ring

1. Close the inlet valve to the filter and release any residual pressure.
2. Disconnect and lock the filter's power supply.
3. Disconnect and lock the filter's compressed air supply and release any residual pressure.
4. Verify that the Suction Scanner is in its lower position. If not remove the electrical motor rear fan-cover, turn the fan manually till the scanner's limit switch plate reaches the lower limit switch.
5. Remove the Split pin (23) and pull out the connecting pin (22).
6. Turn the motor-fan till the drive shaft reaches half way of its movement. The drive shaft is now separated from the Suction Scanner.
7. Unscrew nuts (20 on page 23) and pull the sealing flange (4 on page 23).
8. Remove the used internal O-ring and clean the O-ring seat.
9. Insert a new O-ring (4 on page 23)
10. Apply some grease to the external O-ring and to the shaft.
11. Tighten the sealing flange nuts (4 on page 23).
12. Re-connect the drive shaft to the suction scanner shaft.
13. Reassemble the motor fan cover.
14. Make sure that the filter is correctly reassembled; re-connect the power and the compressed air.
15. Operate the control board and open the filter inlet valve.

C. Maintenance prior to long term cessation of filter operation

The following must be done if the filter will not be operated for more than a month.

1. Operate flushing cycle (If possible, with a closed downstream valve).
2. Disconnect the control board from the power and lock the main switch before the limit switch disc reaches the switch.

3. Release pressure from the filter.
4. Disconnect the compressed air supply and lock the main switch.
5. Grease the drive shaft and the drive bushing.

D. Maintenance prior to re-operation

1. Make sure that the filter is disconnected from power, compressed air and water supply.
2. Grease the drive shaft and the drive bushing.
3. Connect the control board to the mains.
4. Connect the compressed air supply.
5. Connect the filter to its water supply.
6. Perform a General Inspection of the Filter Operation as described above.
7. If necessary, change the Sealing flange Internal O-Ring as described above.

E. Every Six Months

Before beginning this maintenance procedure, carefully read the safety instructions in chapter 2 of this document and make sure that all the workers at the filtration site are fully aware of and comply with, these and any other local safety instructions.

1. Perform a General Inspection of the filter Operation as described above and carefully inspect the filter visually for:
 - a. Proper operation
 - b. Any leakage from the filter housing or accessories
 - c. Abnormal or unusual noises
 - d. Loosen bolts
 - e. Non-smooth turning of the suction scanner
 - f. Unusual load on the filter electrical motor
 - g. Any sign of corrosion on the filter housing or accessories
 - h. Unusual vibrations
 - i. Non-smooth operation of the filter valves, air release valves and check-valves
2. Close the inlet and the outlet valves of the filter. Drain the filter housing and release any residual pressure.
3. Disconnect and lock the filter's power supply.
4. Disconnect and lock the filter's compressed air supply and release any residual pressure.
5. Disassemble the filter as described in the next chapter of this document.
6. Inspect the filter screen and components for any wear and tear.
7. Check the suction scanner and its nozzles.
8. Check the filter bearings.
9. Check the filter housing and lid for any sign of corrosion.
10. Check the filter internal and external coating and pain for damage
11. Replace any damaged component
12. Make sure that your maintenance engineers are aware of even the slightest sign of corrosion in the filter housing, lid or accessories. In such case consider performing a standard pressure vessel tests as required by your local applicable standards.
13. Re-assemble the filter as described in the next section of this document.
14. Perform a complete **COMMISSIONING, START-UP AND FIRST OPERATION** as described earlier in this document.

IMPORTANT!

THE DRIVE SHAFT MUST BE LUBRICATED WITH HEAVY-DUTY, WATER RESISTANT GREASE THAT WILL NOT OXIDIZE. (SHELL, DARINA EP-2 OR SIMILAR)

TROUBLESHOOTING

Before beginning any troubleshooting, carefully read the safety instructions chapter of this document and make sure that all the workers at the filtration site are fully aware of and comply with, these and any other local safety instructions.

The filtration system may enter a malfunction mode in the following cases:

Symptom	Remarks and Actions
<p>Fault due to continuous signal from the pressure differential switch for duration of more than 15 minutes.</p> <p>The fault indication lamp is lighted in red</p>	<p>This fault means that the self-cleaning process is not successful.</p> <p>This fault may be caused by one of the following reasons:</p> <ul style="list-style-type: none"> • The filter is clogged due to heavy dirt load or too high water flow rate. Close the filter's downstream valve. Press the reset button to reset the fault mode. The fault indication lamp is turned off. Perform few consecutive manual flush cycles and monitor the PD signal. Once the filter is clean gradually open the downstream valve and monitor the PD and the flow-rate. Make sure that the filter doesn't exceed its designated flow-rate. • The PD switch is faulty. Ask your qualified electrician to check the PD connections and operation. Replace the switch if found faulty.
<p>The motor protector was activated</p> <p>The fault indication lamp is blinking in red</p>	<p>This fault means that the motor was operated under too high load.</p> <p>Note: All the following checks and actions should be done by a qualified electrician only.</p> <ol style="list-style-type: none"> A. Check the motor power consumption when not loaded. B. Check the limit switches for correct operation and verify that each one of them stop the motor at its designated point. C. Verify 3 phase 380VAC power supply to the control board and the motor. D. Disconnect the drive unit from the suction scanner shaft and verify free turning of the suction scanner. <p>Note: If during this fault a request for flushing is received (Manual, Time or DP) the blinking lamp switches to constant red.</p>
<p>Malfunctioning limit switches</p> <p>The fault indication lamp is blinking in red</p>	<p>Faulty limit switch may not stop the motor at the right point and therefore the motor protection may be activated.</p> <p>Receiving signal from both limit switches at the same time causes fault</p> <ol style="list-style-type: none"> A. Check that the limit switches are not mechanically stuck. B. Ask your qualified electrician to check the wiring and the functionality of the limit switched. <p>Note: If during this fault a request for flushing is received (Manual, Time or DP) the blinking lamp switches to constant red.</p>

DISMANTLING & ASSEMBLING OF FILTER COMPONENTS

Opening the filter and disassembling its inner components is necessary for changing screens, periodic maintenance and repairs. Prior to opening the filter it is recommended to operate a flushing cycle by pressing the "TEST" push button.

Dismantling

1. Disconnect electrical power.
2. Close the water and drain the filter housing.
3. Pull the electrical plug from the solenoid valve (13). Disconnect the raccord connector (17.3).
4. Unscrew the bolts (14.1) and remove exhaust valve (14).
5. Unscrew bolts (12.3) and remove drive unit (12). Put the drive unit on a dry and protected surface near the filter. If the electric cable is not long enough, disconnect it from the motor.
6. Pull out the split pin (20.2) from the connecting pin (20.1) then pull out the connecting pin as well. If the connecting pin is not facing one of the shaft housing windows, turn the drive shaft (11) a little. Use 17mm or 11/16 spanners.
7. Turn the drive shaft (11) counter clockwise so that it will be separated from the suction scanner shaft (7.3).
8. Unscrew bolts (29.2) and remove the limit switches sling without disconnecting and changing the limit switches position.
9. Unscrew bolts (10.5) connecting shaft housing (22) to filter lid (8).
10. Pull up the shaft housing. Put it near the filter, make sure not to damage the limit switches electric wires. If necessary, disconnect the wires from the connecting box (18.9). (Do not forget to mark all wires for proper reconnections).
11. Remove O-ring seal (10.7).
12. Unscrew the housing bolts (8.3) and pull the lid using a crane or other lifting device, which is assembled exactly above the lid center.

Note: the lid must be removed in a horizontal position in order to prevent damage to the suction scanner and the upper bearing seals.
14. Remove the housing O-Ring (2).
15. Pull the scanner (7) and the screen (6) (including screen seals 6.1/6.2).

Extracting the Screen

The screen is heavy. To avoid personal injury use the Extractor and a lifting device to extract the screen.

1. Clean and dry the rubber pads on the Extractor
2. Fold the Extractor upwards (Figure 1).



Figure 1

3. Insert the Extractor into the screen, about a quarter from top. Make sure that the extractor cushions do not touch the stitch found along the screen interior.
4. Pull the extractor up so that it is firmly set against the inside wall of the Screen (Figure 2)



Figure 2:

3. Attach a lifting device to the ring on the Extractor, and extract.

Reassembling the "EBS" filter

Before reassembling, visually check that all components are complete and in good mechanical condition.

1. Install the seals (6.1/6.2) on the screen (6) and insert the screen into the filter housing (1).
2. Position the scanner (7) in the filter housing. Make sure the lower shaft goes through the bearing (5).
3. Locate the housing O-ring (2) properly in its groove.
4. Apply some grease on the suction scanner shaft (7.3) and on the O-rings (8.7 and 24.1).
5. Lower the filter lid (8) carefully toward the filter housing (1) in a horizontal position. Make sure the lid is centered with the suction scanner.
7. Screw the rest of the housing bolts. (8.3) Tightening opposite positioned bolts will achieve proper sealing.
8. Locate the O-ring (10.7) in its groove under the shaft housing (22). Place the bolts (10.5) but do not yet tighten them firmly.
9. Turn the drive shaft (11) clockwise until it reaches the suction scanner shaft. Insert the connecting pin (20.1) to the hole in the drive shaft through the suction scanner shaft hole.
10. Insert the split pin (20.2) in its original position.
11. Make sure that the drive shaft key (11.1) is in its place. Apply grease on it and reassemble the drive unit (12).
12. Tighten firmly the shaft housing bolts (10.5) and the drive unit bolts (12.3) in a controlled and balanced method.
13. Reassemble the limit switches sling (29.3). Make sure the limit switches (29 and 29.1) are tight in their place.
14. Reassemble the exhaust valve (14), solenoid plug and pilot tube.
15. Make sure that all bolts are tightened.
16. Switch on the power. The motor will run until limit plate (28) reaches the lower limit switch (29).
17. Press the "test" push button and make sure the filter works according to stages of cleaning cycle (page 6).
18. Slowly turn on the water, watch and eliminate any leaking.

PARTS LIST – EBS-15000, In-Line

No.	Description	Cat. No.
1	Filter housing	710105-XXXXXX
2	O-ring P2-471	770102-000165
3	Screen base	710105-001763
4	O-ring (P2-237)	770102-000126
5	Lower bearing	710103-002924
5.1	O-ring 71 x 5	770101-000059
6	Weavewire screen	700101-XXXXXX
6.1	Hydraulic seal	770104-000077
6.2	Hydraulic seal	770104-000077
7	Suction scanner assembly	700190-002681
7.1	Slotted spring pin 10 x 60	760105-000024
7.2	Suction scanner nozzle EBS (x6)	710103-002534
7.3	Suction scanner shaft (EBS)	710103-002800
8	Filter Lid	710105-XXXXXX
8.1	Nut M16 (x8)	760102-000067
8.2	Washer 5/8" (Galvanized)(x8)	760103-000069
8.3	Bolt M22 X 60 (x24)	760101-000373
8.4	Washer M22 (x24)	760103-000079
8.5	O-ring (p2-041)	770102-000077
8.6	Upper bearing	710103-002803
8.7	O-ring 71 X 5	770101-000059
9	2" Plug	780101-000779
10	Drive Shaft unit assembly	700190-002677
10.1	Drive shaft housing cover	710105-001779
10.2	Washer 3/8" (x4)	760103-000067
10.3	Spring washer M10 (x4)	760103-000086
10.4	Nut M10 (x4)	760102-000064
10.5	Bolt M16X65 (x8)	760101-000329
10.6	Washer 5/8" (Galvanized)(x8)	760103-000069
10.7	O-ring p2-433	770102-000168
11	Drive shaft (EBS-15000)	710103-002796
11.1	Drive shaft key (EBS-15000)	710103-002807
12	Drive unit (EBS)	720201-000022
12.1	Set screw M6 x 45 (x2)	760101-000520
12.2	Nut M6 (St.St.)(x2)	760102-000085
12.3	BOLT M10 X 40 (x4)	760101-000314
12.4	Washer 3/8" (x4)	760103-000067
13	Solenoid valve 24v AC,"NO"	720103-000177
13.1	L-connector 5/16"x1/8"	720501-000204
13.2	L-connector 5/16"x1/4"	720501-000202
13.3	Connector 5/16" x 1/4"	720501-000206
13.4	Air-brake tube 8 mm (5/16")	720502-000022
13.5	Air-brake tube 8 mm (5/16")	720502-000022
13.6	Connector 1/4"x1/4" (Brass)	710103-000591
14	Hydraulic valve 3" (GAL)	730103-000521
14	Hydraulic valve 3" (RAF)	730103-000519
14	Hydraulic valve 3" (RAM)	730103-000532
14.1	Bolt M16X75 (x8)	760101-000331
14.2	Washer 5/8" (Galvanized) (x8)	760103-000069
14.3	Washer 5/8" (Galvanized) (x8)	760103-000069
14.4	Nut M16 (x8)	760102-000067
14.5	Seal 3"	770103-000046
15	Drive shaft cover (EBS-15000)	710105-001783
15.1	Nut M6 (St.St.)(x2)	760102-000085
16	Ball valve 3/4" (Brass)	730104-000220

No.	Description	Cat. No.
16.1	L-connector 3/4" F-M (Galvanized)	780101-000789
17	3/4" black filter AC, w/o valve	010000-000042
17.1	O-ring P2-112	770102-000082
17.2	Raccord nipple 1/4"	710103-002569
17.3	Raccord nut 3/4"	710103-002570
17.4	Connector 5/16"x1/4"	720501-000206
18	Differential pressure switch	720104-000028
18.1	T-connector 1/8"x5/16"x5/16"	720501-000259
18.2	L-connector 5/16"x1/8"	720501-000204
18.3	Air-brake tube 8 mm (5/16")	720502-000022
18.4	Connector 5/16"x1/4"	720501-000206
18.5	Set screw M6 x 25 (St.St.)(x2)	760101-000545
18.6	Washer M6 (St.St.)(x2)	760103-000094
18.7	Spring washer M6 (St.St.)(x2)	760103-000109
18.8	Nut M6 (St.St.)(x2)	760102-000085
18.9	Electrical junction box	700190-002421
19	Three-way valve 1/4"	730104-000202
19.1	L-connector 5/16"x1/8"	720501-000204
19.3	L-connector 5/16"x1/8"	720501-000204
19.4	Air-brake tube 8 mm (5/16")	720502-000022
19.5	L-connector 5/16"x1/4"	720501-000202
19.6	Pressure gauge 1/4" (DI)	720301-000044
19.7	Air-brake tube 8 mm (5/16")	720502-000022
19.8	T-connector 1/4" (Brass)(x2)	720501-000214
19.9	Manometer valve 1/4"	700190-002336
20.1	Connecting pin (EBS)	710103-002542
20.2	Split pin 2 x 20	760105-000038
21	Sling (EBS CI)	710103-002659
22	Drive shaft housing	710105-001781
24	O-Ring 38 x 4 [external]	770101-000055
24.1	O-Ring 30 x 4 [internal]	770101-000053
25	Set screw M10 x 50 (St.St) (x2)	760101-000527
26	Sealing flange (EBS)	710103-002612
27	Nut M10 (St.St.) (x2)	760102-000087
27.1	Washer M10 (St.St.) (x2)	760103-000097
28	Limit switch plate (EBS-15000)	710103-002816
28.1	Locking ring DIN 471-30	760106-000019
28.2	Locking ring DIN 471-30	760106-000019
29	Limit switch "NC" [lower]	720302-000004
29.1	Limit switch "NC" [upper]	720302-000004
29.2	Bolt M6 x 20 (St.St.) (x2)	760101-000444
29.3	Limit switch sling (EBS-15000)	710103-002814
29.4	Nut M6 (St.St.) (x2)	760102-000085
29.5	Spring washer M6 (St.St.) (x2)	760103-000109
29.6	Washer M6 (St.St.) (x2)	760103-000094
29.7	Washer M6 (St.St.) (x2)	760103-000094
29.8	Bolt M4 x 20 (St.St.) (x2)	760101-000511
29.9	Washer M4 (St.St.) (x2)	760103-000092
29.10	Lock nut M4 (St.St.) (x2)	760102-000099
31	Drive bushing (EBS)	710103-002539
32	Bolt M6 x 35 (St.St.)	760101-000447
32.1	Lock nut M6 (St.St.) (x3)	760102-000101
32.2	Washer M6 (St.St.)	760103-000094
32.3	Washer M6 (St.St.) (x3)	760103-000094

PARTS DRAWING #1

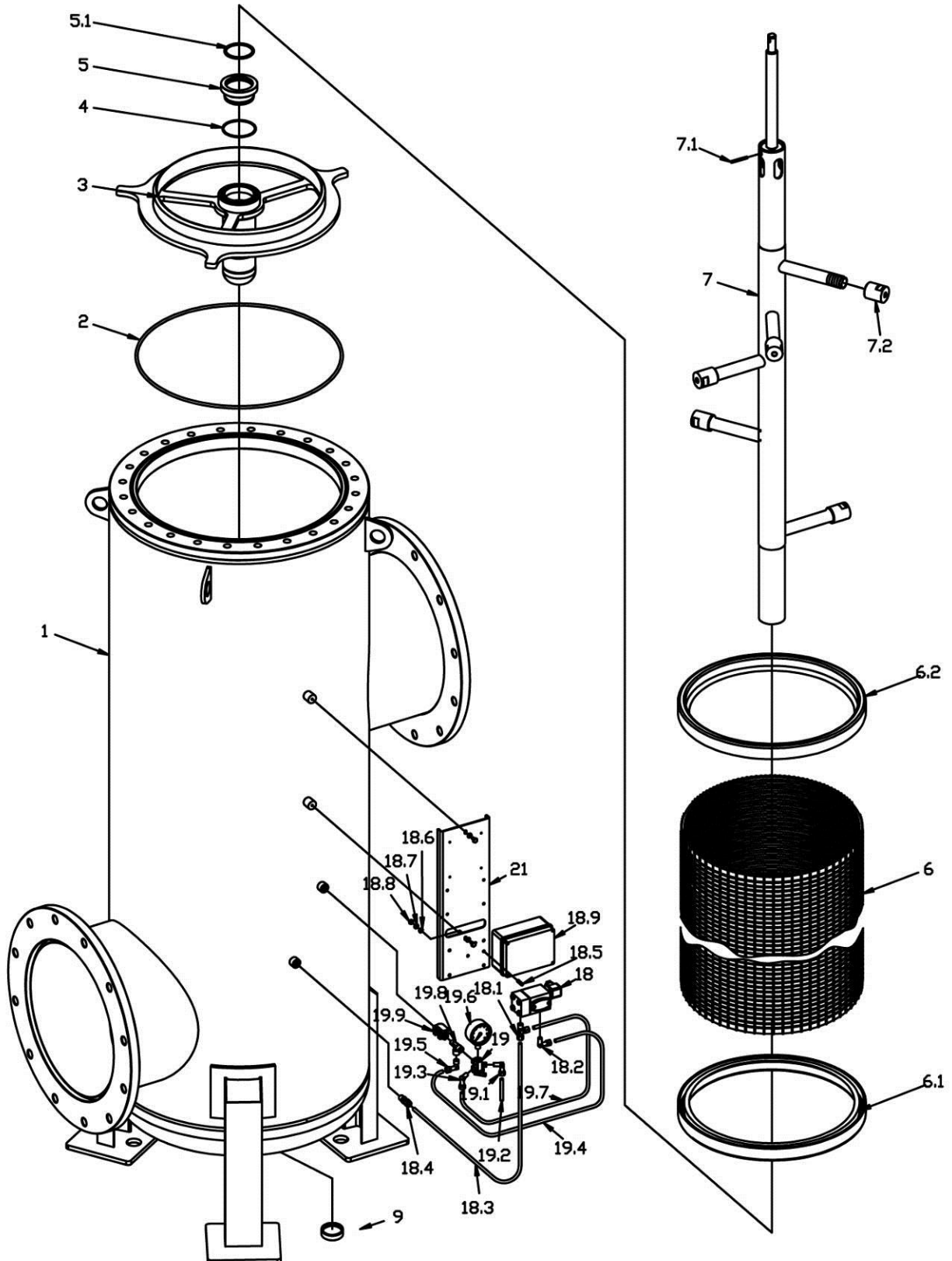

PARTS DRAWING #2

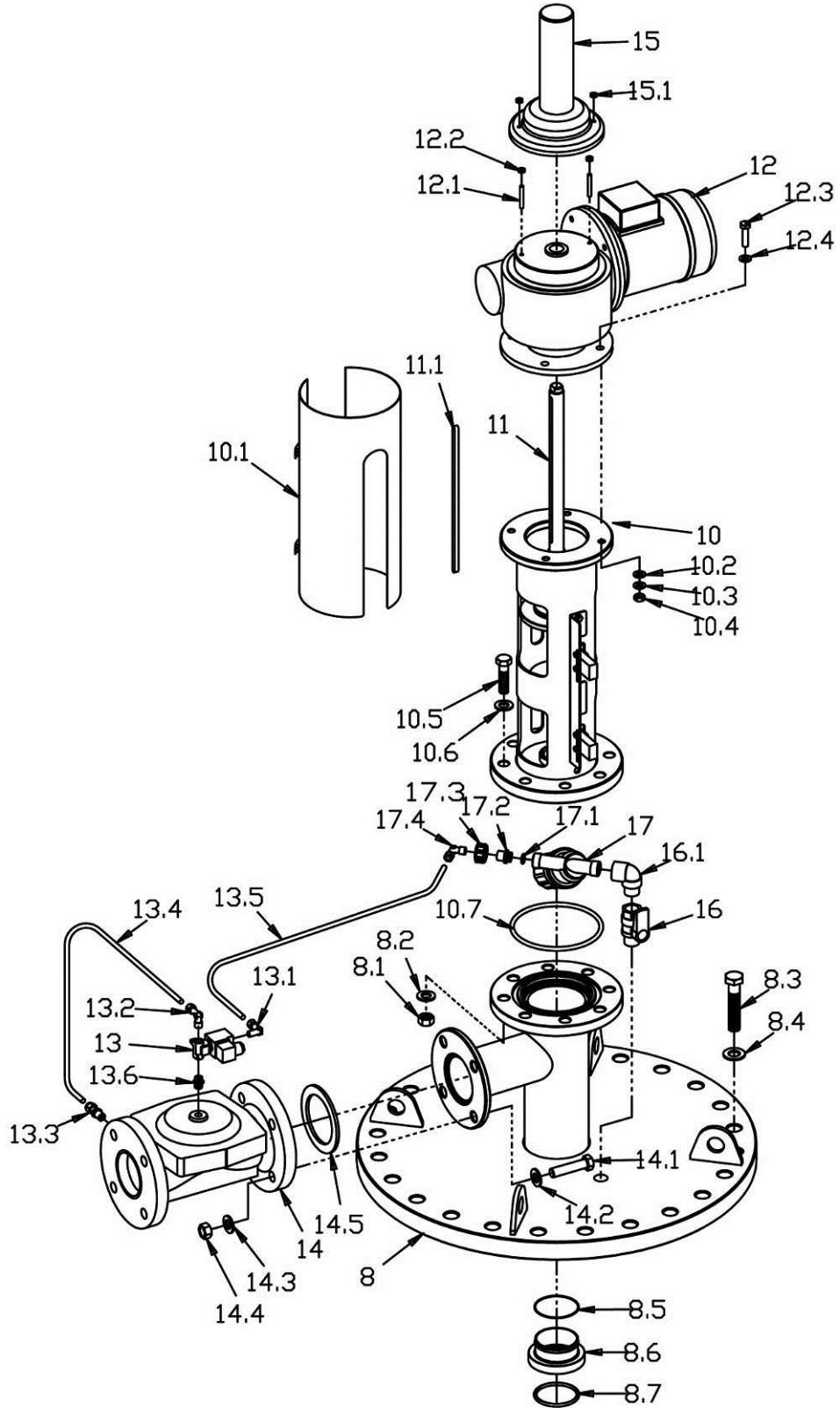

PARTS DRAWING #3

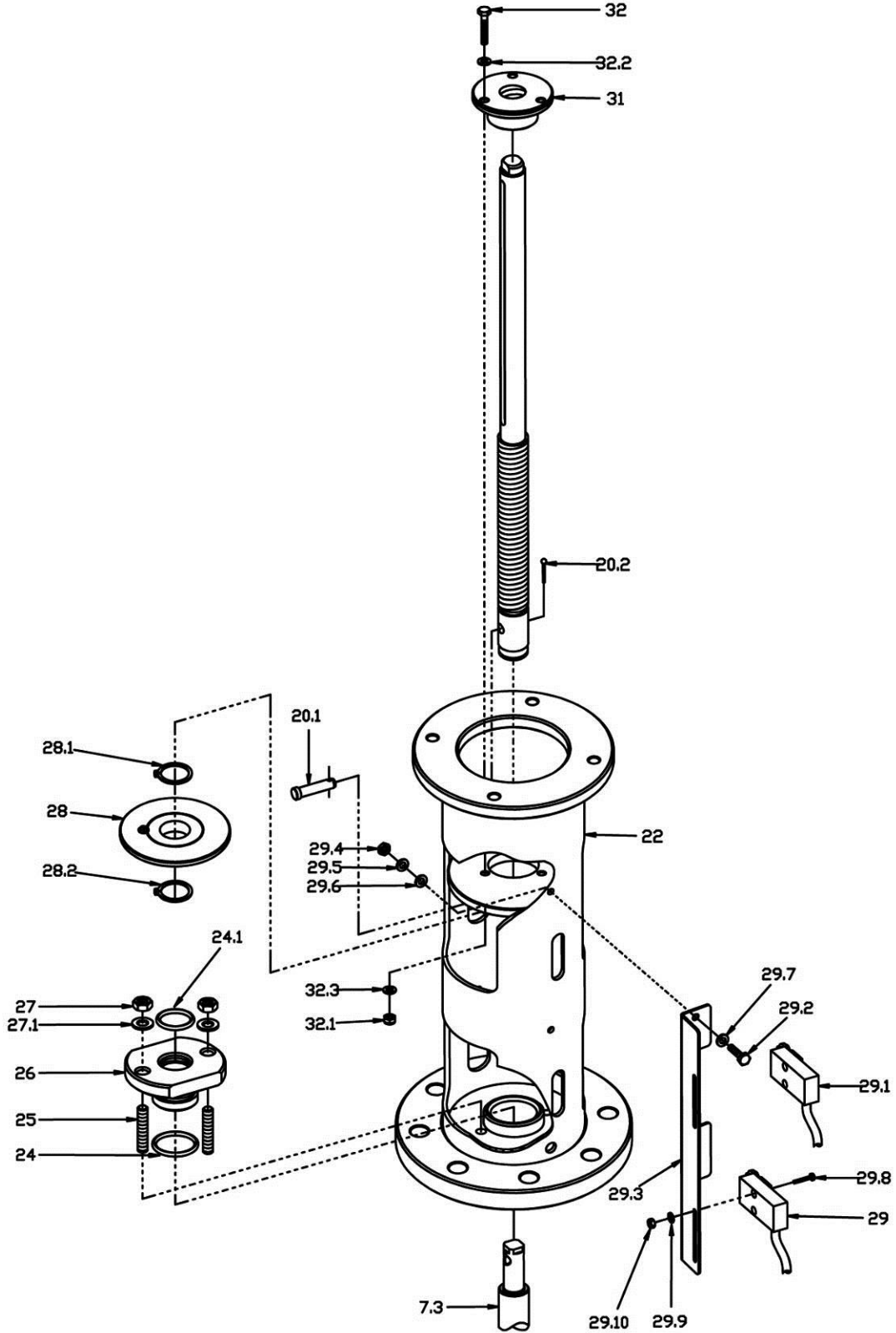

Amiad Limited Warranty

This certificate applies to Amiad Products purchased by You from Amiad or an Amiad authorized Distributor (“**Distributor**”). This limited warranty extends only to the original purchaser, and is not transferable to anyone who subsequently purchases, leases, or otherwise obtains the Product from the original purchaser.

1. Amiad hereby warrants that the Products are and will be free from defects in material and workmanship under normal use and service. Amiad warrants that it will correct manufacturing defects in the Products, in accordance with the conditions set out in this warranty.
2. This warranty is enforceable for a period of 12 months after the date Bill of Lading or equivalent (the “**Warranty Period**”).
3. In the event that during the Warranty Period the Distributor discovers a defect in material and/or workmanship in any Product or part (the “**Defective Product**”), it shall submit a written complaint to Amiad using Amiad's standard customer complaint form. For the receipt of the customer complaint form, the submission of the complaint or any questions please contact your customer service representative.
4. Upon written demand by Amiad the Distributor shall return the Defective Products – or a sample thereof – to Amiad, at Amiad's cost. If the customer ships any such Product, Amiad suggests the customer package it securely and insure it for value, as Amiad assumes no liability for any loss or damage occurring during shipment. Provided however that in the event Amiad determines that the warranty does not apply to such Product, Distributor shall promptly reimburse Amiad for such cost (including freight and customs). Any returned Product or part must be accompanied by the warranty certificate and the purchase invoice. It is clarified that the Distributor may not return the Defective Product unless such return was coordinate and approved by Amiad in advance.
5. Amiad's obligation under this warranty shall be limited to, at its option, the repair or exchange, free of charge, of the Product or any part which may prove defective under normal use and service during the Warranty Period. The provision of a repaired or replacement Product during the Warranty Period will result in an extension of the Warranty Period by an additional period of 12 months, provided that the total accumulated Warranty Period shall in any event be no more than 18 months from the original Bill of Lading.
6. This warranty is valid on the condition that the Products are installed according to Amiad's instructions as expressed in Amiad's instruction manuals and according to the technical limitations as stipulated in Amiad's literature or as stated by a representative of Amiad.
7. This warranty will not apply to damaged or defective Products resulting from or related to:
 - (i) Fire, flood, power surges or failures or any other catastrophe/and or unforeseen occurrence, such as but not limited to those for which the customers are customarily insured;
 - (ii) Fault, abuse or negligence of the customer;
 - (iii) Customer's responsibilities, including the failure of the intake water to meet the agreed standards, as set forth in a written document, approved by Amiad or improper storage.
 - (iv) Improper or unauthorized use of the Product or related parts by the customer, including the customer's failure to operate the Product in conformity with the recommendations and instructions of Amiad, as set forth in Amiad's manuals and other written materials, the operation of the Product other than by a trained and qualified operator, or improper installation of the Product by a third party not authorized by Amiad;
 - (v) Performance by the customer of maintenance and other services other than by a trained and qualified advanced operator, or other than in conformity with the recommendations and instructions of Amiad, or other than in accordance with procedures defined in the literature supplied for Products;
 - (vi) Any alteration, modification foreign attachment to or repair of the Products, other than by Amiad or its authorized technical representatives.
8. In no event shall Amiad be liable to the customer or any third party for any damages, including indirect, special, exemplary, punitive or consequential damages, or lost profits arising out of or in connection with this warranty, or arising out of or in connection with the Product's performance or failure to perform, even if it has been advised of the possibility of such damages.
9. Amiad will be excused for failure to perform or for delay in performance hereunder if such failure or delay is due to causes beyond its reasonable control or force majeure preventing or hindering performance.
10. The limited warranty set forth herein is the only warranty given by Amiad and is provided in lieu of any other warranties created by any documentation, packaging or otherwise.
11. Amiad makes no warranty whatsoever in respect of accessories or parts not supplied by Amiad. In the event that Amiad is required to correct a defective Product or product not covered by this warranty, it will do so solely in consideration for additional fees.

Алматы (7273)495-231
Ангарск (3955)60-70-56
Архангельск (8182)63-90-72
Астрахань (8512)99-46-04
Барнаул (3852)73-04-60
Белгород (4722)40-23-64
Благовещенск (4162)22-76-07
Брянск (4832)59-03-52
Владивосток (423)249-28-31
Владикавказ (8672)28-90-48
Владимир (4922)49-43-18
Волгоград (844)278-03-48
Вологда (8172)26-41-59
Воронеж (473)204-51-73
Екатеринбург (343)384-55-89

Иваново (4932)77-34-06
Ижевск (3412)26-03-58
Иркутск (395)279-98-46
Казань (843)206-01-48
Калининград (4012)72-03-81
Калуга (4842)92-23-67
Кемерово (3842)65-04-62
Киров (8332)68-02-04
Коломна (4966)23-41-49
Кострома (4942)77-07-48
Краснодар (861)203-40-90
Красноярск (391)204-63-61
Курск (4712)77-13-04
Курган (3522)50-90-47
Липецк (4742)52-20-81

Магнитогорск (3519)55-03-13
Москва (495)268-04-70
Мурманск (8152)59-64-93
Набережные Челны (8552)20-53-41
Нижний Новгород (831)429-08-12
Новокузнецк (3843)20-46-81
Ноябрьск (3496)41-32-12
Новосибирск (383)227-86-73
Омск (3812)21-46-40
Орел (4862)44-53-42
Оренбург (3532)37-68-04
Пенза (8412)22-31-16
Петрозаводск (8142)55-98-37
Псков (8112)59-10-37
Пермь (342)205-81-47

Ростов-на-Дону (863)308-18-15
Рязань (4912)46-61-64
Самара (846)206-03-16
Санкт-Петербург (812)309-46-40
Саратов (845)249-38-78
Севастополь (8692)22-31-93
Саранск (8342)22-96-24
Симферополь (3652)67-13-56
Смоленск (4812)29-41-54
Сочи (862)225-72-31
Ставрополь (8652)20-65-13
Сургут (3462)77-98-35
Сыктывкар (8212)25-95-17
Тамбов (4752)50-40-97
Тверь (4822)63-31-35

Тольятти (8482)63-91-07
Томск (3822)98-41-53
Тула (4872)33-79-87
Тюмень (3452)66-21-18
Ульяновск (8422)24-23-59
Улан-Удэ (3012)59-97-51
Уфа (347)229-48-12
Хабаровск (4212)92-98-04
Чебоксары (8352)28-53-07
Челябинск (351)202-03-61
Череповец (8202)49-02-64
Чита (3022)38-34-83
Якутск (4112)23-90-97
Ярославль (4852)69-52-93

Россия +7(495)268-04-70

Казахстан +7(7172)727-132

Киргизия +996(312)96-26-47

<https://amiad.nt-rt.ru> || afv@nt-rt.ru