

Алматы (7273)495-231
Ангарск (3955)60-70-56
Архангельск (8182)63-90-72
Астрахань (8512)99-46-04
Барнаул (3852)73-04-60
Белгород (4722)40-23-64
Благовещенск (4162)22-76-07
Брянск (4832)59-03-52
Владивосток (423)249-28-31
Владикавказ (8672)28-90-48
Владимир (4922)49-43-18
Волгоград (844)278-03-48
Вологда (8172)26-41-59
Воронеж (473)204-51-73
Екатеринбург (343)384-55-89

Иваново (4932)77-34-06
Ижевск (3412)26-03-58
Иркутск (395)279-98-46
Казань (843)206-01-48
Калининград (4012)72-03-81
Калуга (4842)92-23-67
Кемерово (3842)65-04-62
Киров (8332)68-02-04
Коломна (4966)23-41-49
Кострома (4942)77-07-48
Краснодар (861)203-40-90
Красноярск (391)204-63-61
Курск (4712)77-13-04
Курган (3522)50-90-47
Липецк (4742)52-20-81

Магнитогорск (3519)55-03-13
Москва (495)268-04-70
Мурманск (8152)59-64-93
Набережные Челны (8552)20-53-41
Нижний Новгород (831)429-08-12
Новокузнецк (3843)20-46-81
Новосибирск (383)227-86-73
Омск (3812)21-46-40
Орел (4862)44-53-42
Оренбург (3532)37-68-04
Пенза (8412)22-31-16
Петрозаводск (8142)55-98-37
Псков (8112)59-10-37
Пермь (342)205-81-47

Ростов-на-Дону (863)308-18-15
Рязань (4912)46-61-64
Самара (846)206-03-16
Санкт-Петербург (812)309-46-40
Саратов (845)249-38-78
Севастополь (8692)22-31-93
Саранск (8342)22-96-24
Симферополь (3652)67-13-56
Смоленск (4812)29-41-54
Сочи (862)225-72-31
Ставрополь (8652)20-65-13
Сургут (3462)77-98-35
Сыктывкар (8212)25-95-17
Тамбов (4752)50-40-97
Тверь (4822)63-31-35

Тольятти (8482)63-91-07
Томск (3822)98-41-53
Тула (4872)33-79-87
Тюмень (3452)66-21-18
Ульяновск (8422)24-23-59
Улан-Удэ (3012)59-97-51
Уфа (347)229-48-12
Хабаровск (4212)92-98-04
Чебоксары (8352)28-53-07
Челябинск (351)202-03-61
Череповец (8202)49-02-64
Чита (3022)38-34-83
Якутск (4112)23-90-97
Ярославль (4852)69-52-93

Россия +7(495)268-04-70

Казахстан +7(7172)727-132

Киргизия +996(312)96-26-47

<https://amiad.nt-rt.ru> || afv@nt-rt.ru

3"-4" Spin Klin Angle Apollo Battery

Service & Maintenance Manual



Table of Contents

<u>Subject</u>	<u>Page No.</u>
1. Introduction	3
2. Safety Instructions	3
3. Description and Operation	4
4. Technical Data	6
5. Headloss Chart.....	6
6. P & ID.....	7
7. System Maintenance	8
8. Troubleshooting	13
Limited Warranty	15

1. Introduction

General

Arkal Filtration Systems congratulates you on purchasing the Spin Klin Apollo battery. All Arkal's filters are easy to install, use and service and don't require special skills to operate them.

For operation and maintenance of the filter please follow the instructions in this manual.

This Arkal Spin Klin Apollo battery is an automatic self-cleaning filter designed for non-hazardous liquids only and within the pressure and temperature framework described in the specifications table.

2. Safety Instructions

Prior to installation or handling of the filter, read carefully the Installation and Operation Instructions carefully.

1. Confirm filter draining prior to service.
2. Take precautions while lifting, transporting or installing the filter.
3. Installation of the filter should be performed so as to avoid direct water splashing on any of the filter parts and especially on the electronic control unit.
4. Confirm that filter weight, when full, meets the support construction requirements.
5. Prior to installation confirm that line pressure matches filter's operational pressure.
6. During installation, use standard flanges and connections only.
7. Check that all filter flange bolts are properly secured.
8. Please note, the filter enters a flushing mode automatically, without prior warning.
9. Use original parts only when servicing the filter.
10. Arkal cannot accept responsibility for any changes or modifications to the equipment.

Special Note

Before opening the filter lock, check that there is no pressure in the filter.

3. Description and Operation

Table of Filtration Grades of the Discs and Color Code

Color Code	Blue	Yellow	Red	Black
Mesh	40	80	120	140
Micron	400	200	130	100

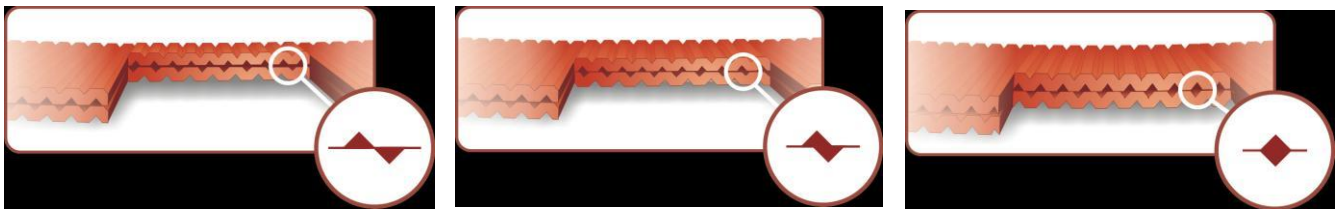

Spin Klin Spine - The Core of the Spin Klin Filtration System

The Spin Klin[®] discs are stacked on the Spin Klin[®] spine. The discs are color-coded according to micron size, and are assembled to suit your water filtration requirements. The spine assembly has a spring compression unit and an internal piston, which operate during alternate filtration or backwash modes. The spine assembly is specially designed to compress the micron housing. Inside the housing a spring and the pressure difference compress the discs tightly during the filtration process, forcing the water to flow between the grooves and trap the solids.

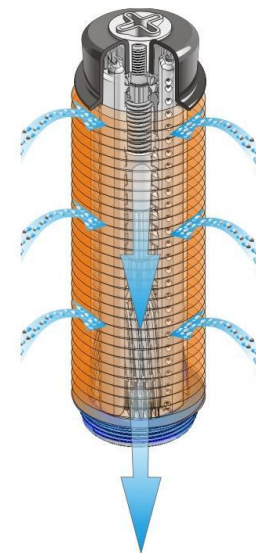

Spin Klin Automatic Backwash Operation

Activated by a predefined command (differential pressure or time) alternate units of the Spin Klin[®] system go into backwash mode. The inlet valve is shut as the drain is automatically opened. During the backwash process, the compression spring is released and the pressure difference is eliminated. The spine piston rises up, releasing the pressure on the discs. Tangential jets of clean water are pumped at high pressure in the opposite direction through nozzles at the center of the spine. The discs spin free and clear, loosening the trapped solids. Solids are quickly and efficiently flushed out through the drain.

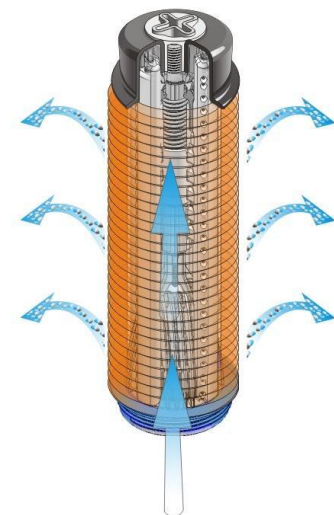

3.3 Mode of Operation

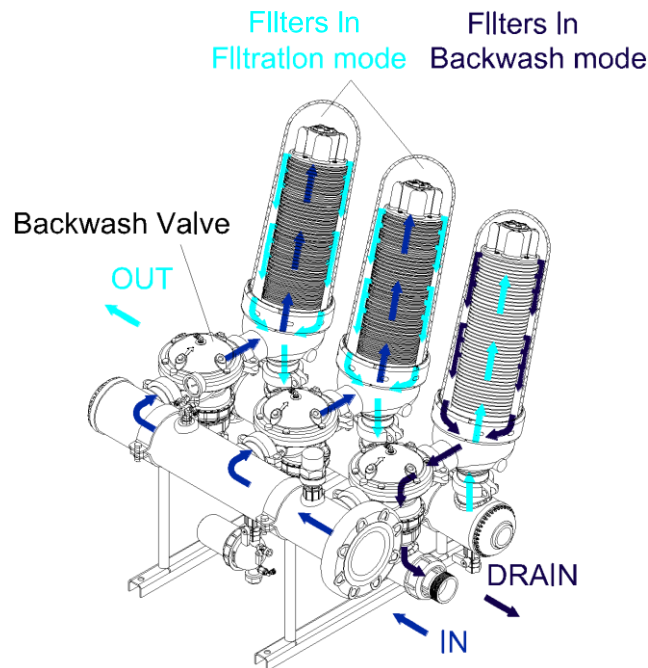

Filtration Process

During the filtration process the water flows through the inlet manifold, reaching the filters through the backwash valves. The filtered water flow through the outlet manifold into the system.

Backwash Process

The backwash process begins with a signal from the control unit activated by the pressure difference between the inlet and outlet or by time.

This signal is transported to the booster valve (assembled on 4"x 3" inlet valve No.1).

The booster valve opens, causing the No.1 valve to close the 4" inlet to the filter and open the 3" drain port.

Filter No.1 is now in a backwash mode.

The Spin Klin spine in filter No.1 operate simultaneously, releasing the compressed discs. Tangential jets of water are pumped against the discs, causing them to spin fast and free, flushing trapped solids out to the drain.

The filtered backwash water is supplied from the other filters through the outlet manifold.

The contaminated water from the backwashed filter drains through the drainage manifold.

Backwash time per filter is between 20 -25 seconds. When the time elapses the control unit stops the backwash signal to the solenoid.

The solenoid releases the water pressure signal allowing the inlet valve and the discs of the spine to return to filtration mode.

Once filter No.1 is in the filtration position again the control unit sends a signal to begin the backwash process in filter No.2.

4. Technical Data - 3"-4" Spin Klin Angle Apollo

			3 Units	4 Units	5 Units	6 Units	7 Units	8 Units
Max. pressure <input type="checkbox"/>		bar/psi	10/145	10/145	10/145	10/145	10/145	10/145
Min. backwash pressure <input type="checkbox"/> <input type="checkbox"/>		bar/psi	2/29	2/29	2/29	2/29	2/29	2.0/29
Max. recommended flow rate	400-130 μ	m ³ /h/gpm	120/530	160/705	200/880	240/1,055	280/1,235	320/1,420
	100 μ	m ³ /h/gpm	110/485	145/639	180/793	215/947	250/1,100	290/1,277
Filtration surface area		cm ² /in ²	7,860/1,220	10,480/1,625	13,100/2,030	15,720/2,435	18,340/2,840	20,960/3,245
Filtration volume		cm ³ /in ³	9,426/575	12,568/767	15,710/959	18,852/1,150	21,994/1,342	25,136/1,534
Backwash flow per filter		m ³ /h/gpm	24/105	24/105	24/105	24/105	24/105	24/105
Backwash volume		m ³ /gallon	0.4/105	0.5/130	0.7/185	0.8/210	0.9/235	1/265
System length - L		mm/inch	1,160/46	1,520/60	1,920/76	2,280/90	2,660/105	3,040/120
System width - W		mm/inch	1,048/41	1,048/41	1,118/44	1,118/44	1,160/46	1,160/46
System height - H		mm/inch	1,201/47	1,201/47	1,285/51	1,285/51	1,307/51	1,307/51
Standard diameter		mm/inch	160/6	160/6	200/8	200/8	280/10	280/10

- Max. pressure 10 bar - 25 t
- depended on the water quality

5. Batteries Headloss Chart - 130 micron, 4" Spin Klin Angle Apollo

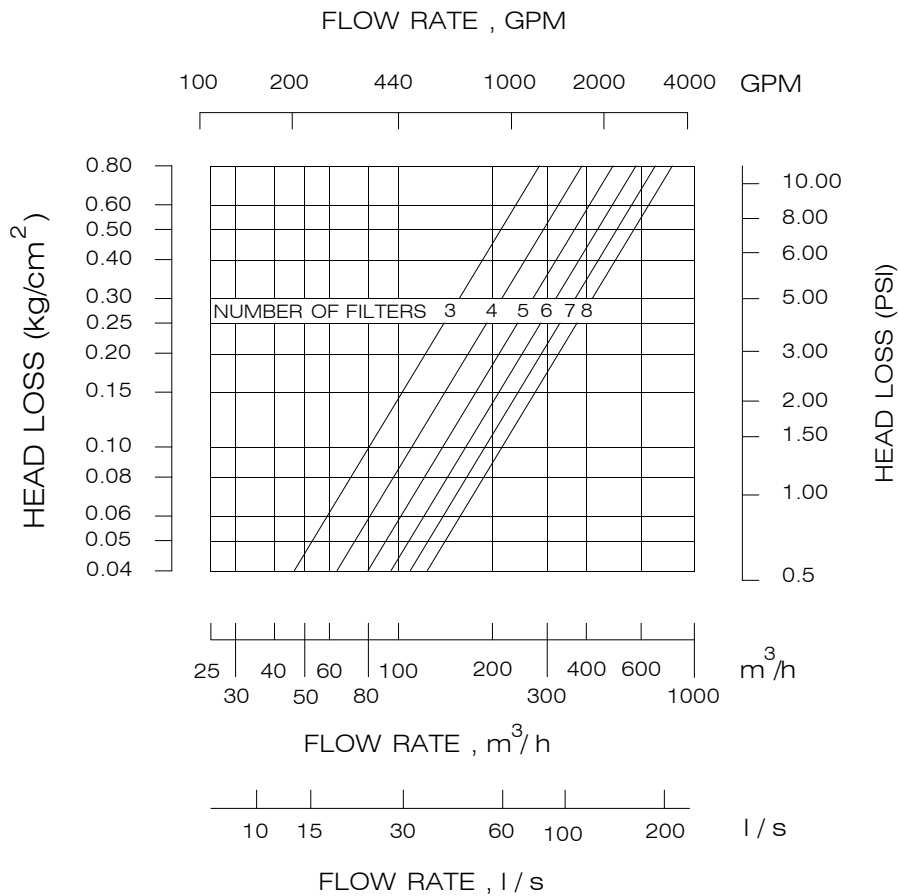

6. P & ID

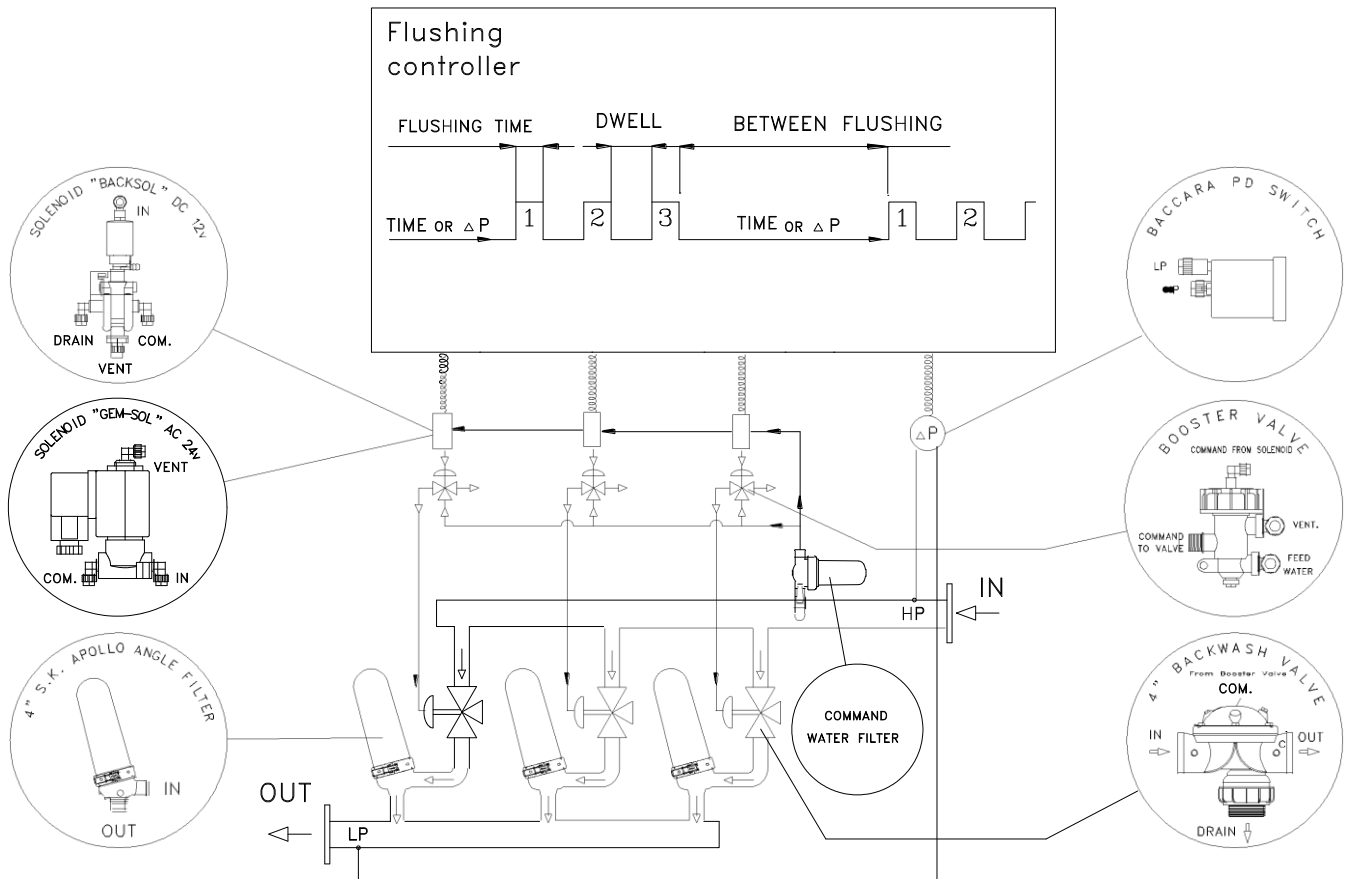

Control

- Refer to the manufacturer's handbook before installing the controller.
- Make sure that the voltage of both the solenoid unit and controller are correct.
- Set the manual operation button to automatic.
- Check that the ΔP hydraulic switch HIGH and LOW pressure lines are correctly connected to the appropriate ports.
- Set the starting backwash switch to ΔP 5-7 meters (6 - 8 psi).
- Set the controller to a flush time of 20-25 seconds and a dwell time of 10 seconds. These settings may require adjustment to conform to local water conditions. Typically, a 1 to 3 hour interval between backwashes is recommended.

7. Apollo Spin Klin - System Maintenance

Monthly Maintenance

Check inlet /outlet pressures:

In case the pressure differential is above 5 m / 7 PSI.

Activate automatic backwash of the Spin Klin filter battery.

In the event that the pressure differential remains high check for possible failures.

Check for leakages from the drain manifold:

In case there is a leakage of water during the filtration stage, check for possible failure at the backwash valve seals.

Backwash controller performance:

Check that the controller timing parameters are correctly adjusted and activate automatic backwash cycle. In the event of possible failure at the backwash controller, check for possible failures.

Cleaning of the Command Filter:

Close the command filter inlet valve. Release the static pressure by opening the drain valve.

Remove the cover. Thoroughly clean the filter element and then reassembly the command filter element and cover, then open the inlet valve.

Winterization:

In order to prevent the filter battery becoming damaged during water freezing – drain all the water from the filter battery, the command filter and the backwash valves.

SEASONAL MAINTENANCE - DISCS

To guarantee thorough cleaning the following steps should be taken:

Close the water inlet after backwashing the systems. Make sure that there is no pressure in the system, pull out the safety pin, open the clamp and remove the cover. **(Figure 1)**

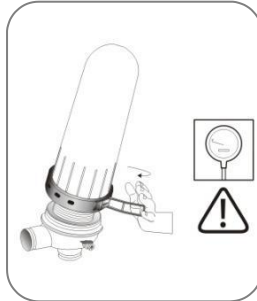

Figure 1

Unscrew the butterfly nuts on the filtration elements. **(Figure 2)**

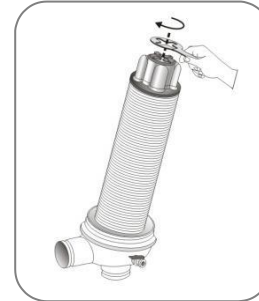

Figure 2

Remove the tightening cylinders. **(Figure 3)**

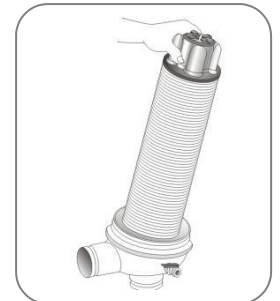

Figure 3

Remove the disc sets (for convenience we recommend using a plastic bag). **(Figure 4-5)**

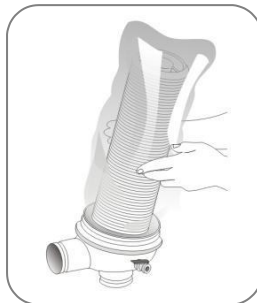

Figure 4

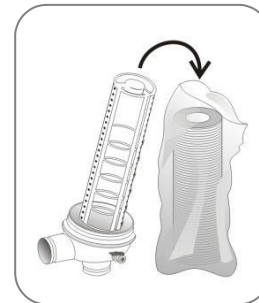

Figure 5

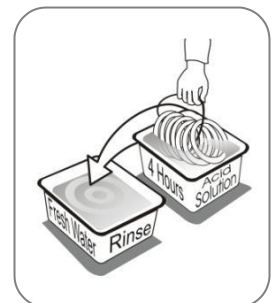

Figure 6

Tie each set on a string and place them in a cleaning solutions (HCL, Chlorine, or other) refer to "Cleaning Recommendations Clogged Filtration Discs". **(Figure 6)**

Ensure that the correct quantities of discs are assembled on the spines: when the discs are pressed with two hands, the top disc should be level with the imprinted circle on the outside of the spine. **(Figure 7)**



Figure 7

Tighten the butterfly nut until the stopping point. **(Figure 8)**

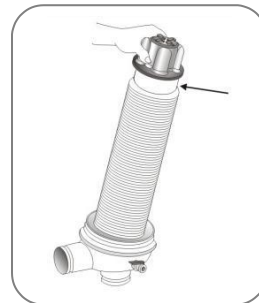

Figure 8

Place the filter cover on the filter body and secure it with a slight clockwise rotation. Reposition clamp onto the cover and close using the lever. **(Figure 9-10)**



Figure 9

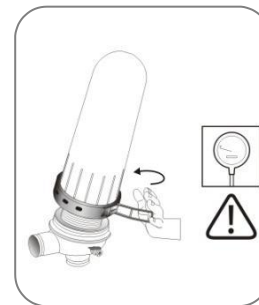

Figure 10

Tighten the clamp. Insert the safety pin. **(Figure 11)**

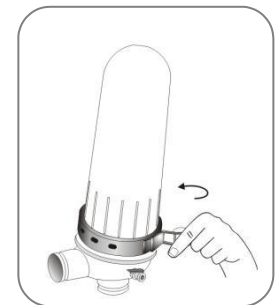

Figure 11

Attention:

When carrying out any of the following seasonal maintenance, service, or cleaning the discs – After backwashing the system and after closing the water inlet, **make sure that there is no pressure in the system!**

Please Note:

- Before removing the cover you may experience the vacuum phenomenon – which will make the removing of the cover very difficult or almost impossible.
- Do Not** - insert any sharp tools (objects) in between the cover and the body! You may damage the hydraulic seal and the cover!
- In order to remove the cover easily – **you should drain the water from the filter!**
- You may drain the filter through the drain valve located on the filter body, once the filter is empty the cover can then be removed safely and easily.



Cleaning Recommendations for Clogged Filtration Discs

Water-formed deposits may cause clogging of the filter discs. The formation of these deposits depends on the quality of the filtered water and environmental conditions like temperature, pH, light, duration of filtration and more.

Common water-formed deposits are:

- Biological or organic deposits (mostly mucous or oily to the touch, beige, brown or green in color)
- Iron oxide (rust) or other metal oxides
- Carbonates (white or gray deposit)
- Combinations of the above

If these deposits cannot be eliminated by pretreatment of the water, we recommend the following cleaning procedure:

Material and Equipment

- A well ventilated working place.
- 2 small containers (1 liter), 2 large containers (15 liter) and a stirring stick, all resistant to chemicals, preferably of polypropylene.
- Plastic rope to tie up the disc.
- Sodium Hypochlorite NaOCl -
Strong oxidizing liquid, commercial concentration: 10%.
Oxidizes and removes organic and biological deposits.
- Hydrochloric Acid HCl -
Very corrosive liquid, commercial concentration: 30%.
Dissolves and removes carbonates, iron oxide, and other deposits.
- Safety equipment: safety glasses, gloves, long pants, long sleeved shirt and shoes.

ATTENTION!

While working with chemicals protect yourself with the necessary safety equipment:

- Safety glasses, gloves, protective clothing
- Work in a well ventilated area
- Follow the manufacturer's instructions

Cleaning Organic and Biological Deposits

- Open the filter and remove dirty discs.
Attention – Never open the filter before the pressure has been released.
- Arrange the discs loosely on the plastic rope
- Prepare a 5% Sodium Hypochlorite solution:
 - 1) Pour 5 liters of water into one of the large containers.
 - 2) Add 5 liters of Sodium Hypochlorite (10%) into the water.
- Soak the discs in the solution so that both sides are covered. To achieve maximum cleaning, agitate the discs several times with a stirring stick.
- Contact time with cleaning solution: up to 8 hours
- Remove the discs carefully from the solution, put them in the second large container and rinse them very well with clean water before placing them back in the filter.
- We recommend flushing the cleaned discs again in the filter to ensure that all chemical residues are removed.

The cleaning solution can be used for several sets of discs. As the cleaning activity of the solution deteriorates, it may be necessary to soak the discs for a longer time.

Cleaning Carbonates and Iron Deposits

- Open the filter and remove the dirty discs.
- Arrange the discs loosely on the plastic rope.
- Prepare a 5% Solution of Hydrochloric Acid:
 - 1) Pour 10 liters of water into one of the large containers.
 - 2) Carefully add 2 liters of Hydrochloric Acid (30%) into the water.Soak the discs in the solution so that both sides will be covered.

PLEASE NOTE: Carbonates react violently with hydrochloric acid (foaming, gas evolution).

To achieve maximum cleaning, agitate the discs several times with a stirring stick.
- Contact time with cleaning solution: 1 - 8 hours.
- Remove the discs carefully from the solution and rinse them well with clean water before placing them back in the filter.
- We recommend flushing the cleaned discs again in the filter to ensure that all chemical residues are removed.

The cleaning solution can be used for several sets of discs. It may be necessary to soak the discs for a longer period of time as the cleaning activity of the solution deteriorates.

Cleaning Complex Deposits

If the composition of the deposit is not known, perform the following test:

- Take 5 discs for the test.
- Soak 2 discs in a 5% Sodium Hypochlorite Solution.

Preparation of the solution:
Pour 1 cup of water into a small container, then add 1 cup of Sodium Hypochlorite (10% NaOCl).
- Soak 2 discs in a 5% Hydrochloric Acid Solution.

Preparation of the solution:
Pour 2½ cups (= 500ml) of water into a small container, then add carefully ½ cup (= 100ml) of Hydrochloric Acid (30% HCl).
- Keep one disc as a control.
- Observe the cleaning process:

If one of the solutions removes all of the deposit, clean the discs in that solution according to the instructions above.

If neither solution removes the deposit completely, continue with the test procedure.
- Remove the discs from both solutions, rinse them well with water and soak them in the second solution: put the two discs, which have been in the Sodium Hypochlorite Solution, in the Hydrochloric Acid Solution, and the other way round.
- Check the cleaning process:

If one of the treatments removes all of the deposit, clean all of the discs following the same two-step procedure in the exact same order. Rinse the discs well between the two cleaning processes. If the deposit hasn't been completely removed, send a set of untreated discs to the laboratory for further examination.

8. Troubleshooting

No Backwash Operation

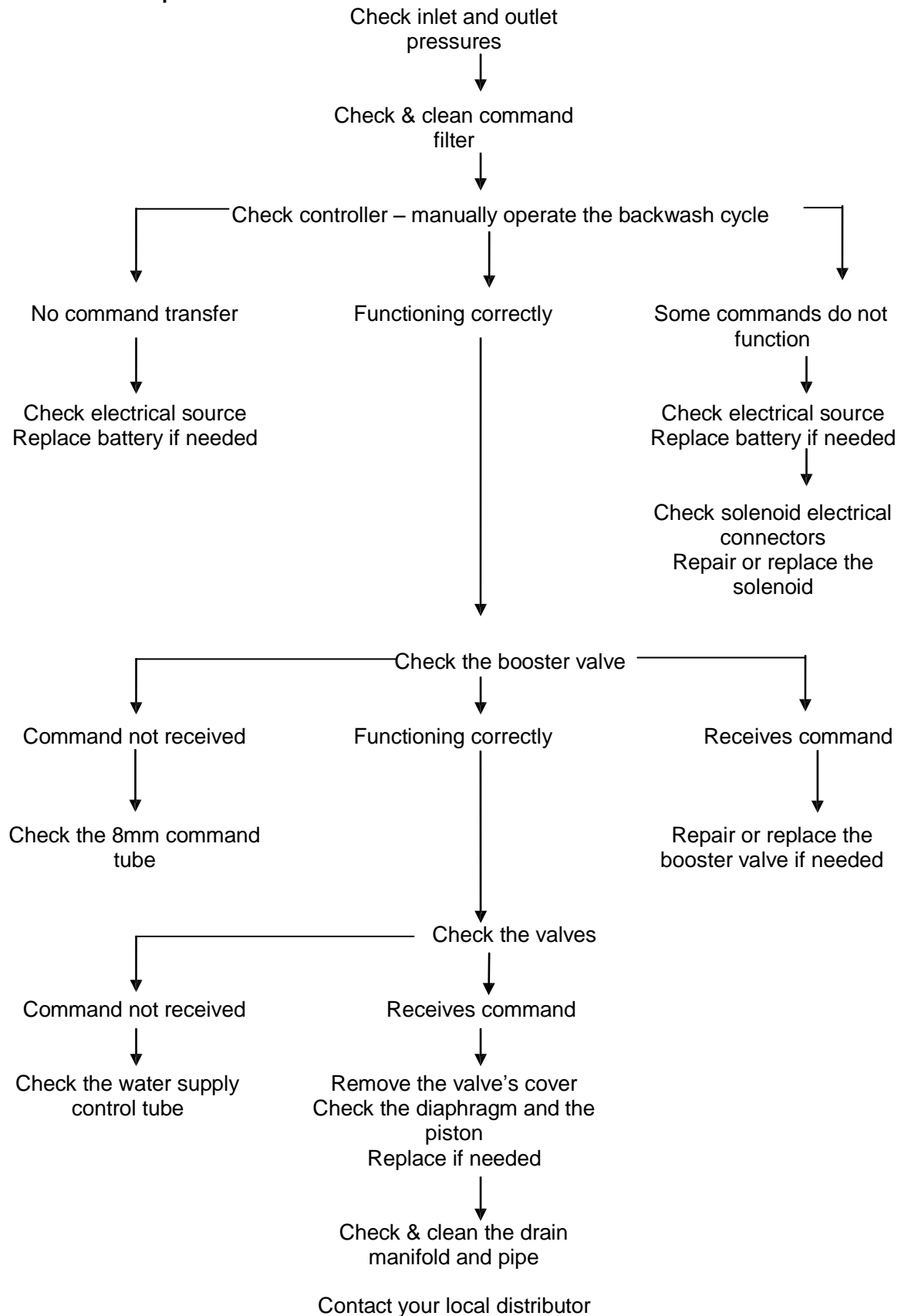

Identifying Malfunctions in the Apollo system

Continuous or Non-stop Backwashing

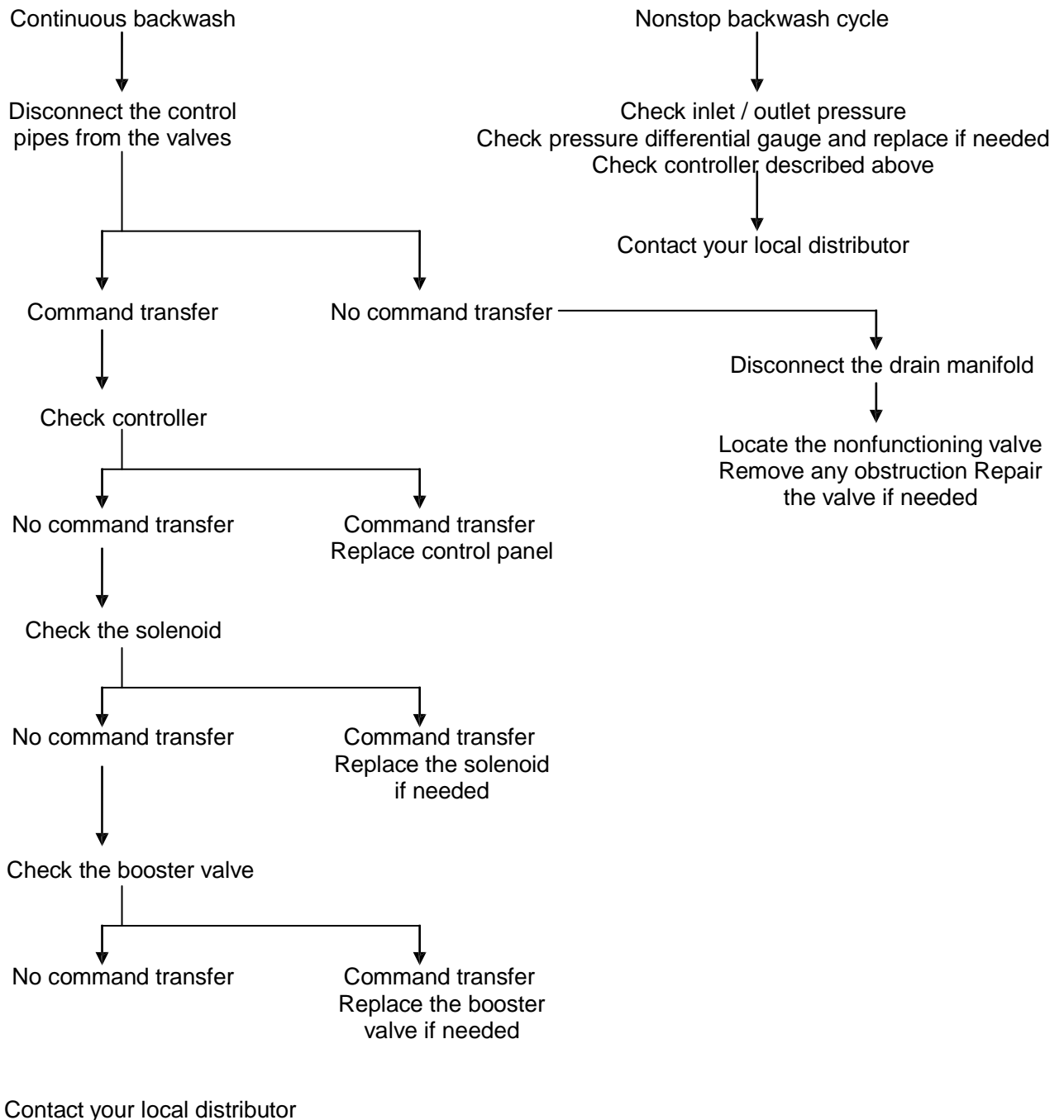

Limited Warranty

ARKAL FILTRATION SYSTEMS ("ARKAL FILTRATION SYSTEMS") warrants to the original end user ("CUSTOMER") who purchased ARKAL FILTRATION SYSTEMS products directly from Arkal or through one of its authorized distributors, that such products will be free from defect in material and/or workmanship for the term set forth below, provide that such products are properly installed, used and maintained in accordance with ARKAL FILTRATION SYSTEMS instructions, written or verbal.

Should such products prove defective within one year from the original purchase date by the customer, and subject to receipt by ARKAL FILTRATION SYSTEMS or its authorized representative, of written notice thereof from the customer within 30 days of discovery of such defect or failure - ARKAL FILTRATION SYSTEMS will repair or replace, at its sole discretion, any item proven to be defective.

ARKAL FILTRATION SYSTEMS shall not be liable, nor does this warranty extend to any consequential or incidental damages or expenses of any kind or nature, regardless of the nature thereof, including without limitation, injury to persons or property, loss of use of the products, loss of goodwill, loss of profits or any other contingent liabilities of any kind or character alleged to be the cause of loss or damage to the purchaser.

This warranty does not cover damage or failure caused by misuse, abuse or negligence, nor shall it apply to such products upon which repairs or alterations have been made by other than an authorized ARKAL FILTRATION SYSTEMS representative.

This warranty does not extend to components, parts or raw materials used by ARKAL FILTRATION SYSTEMS but manufactured by others, which shall be only to the extent warranted by the manufacturer's warranty.

No agents or representatives shall have the authority to alter the terms of this warranty nor to add any provisions to it not contained herein or to extend this warranty to anyone other than ARKAL FILTRATION SYSTEMS customers.

THERE ARE NO WARRANTIES, EXPRESS OR IMPLIED, EXCEPT THIS WARRANTY WHICH IS GIVEN IN LIEU OF ANY OTHER WARRANTIES, EXPRESS OR IMPLIED, INCLUDING ANY IMPLIED WARRANTY OF MERCHANTABILITY AND FITNESS FOR A PARTICULAR PURPOSE.

Алматы (7273)495-231
Ангарск (3955)60-70-56
Архангельск (8182)63-90-72
Астрахань (8512)99-46-04
Барнаул (3852)73-04-60
Белгород (4722)40-23-64
Благовещенск (4162)22-76-07
Брянск (4832)59-03-52
Владивосток (423)249-28-31
Владикавказ (8672)28-90-48
Владимир (4922)49-43-18
Волгоград (844)278-03-48
Вологда (8172)26-41-59
Воронеж (473)204-51-73
Екатеринбург (343)384-55-89

Иваново (4932)77-34-06
Ижевск (3412)26-03-58
Иркутск (395)279-98-46
Казань (843)206-01-48
Калининград (4012)72-03-81
Калуга (4842)92-23-67
Кемерово (3842)65-04-62
Киров (8332)68-02-04
Коломна (4966)23-41-49
Кострома (4942)77-07-48
Краснодар (861)203-40-90
Красноярск (391)204-63-61
Курск (4712)77-13-04
Курган (3522)50-90-47
Липецк (4742)52-20-81

Магнитогорск (3519)55-03-13
Москва (495)268-04-70
Мурманск (8152)59-64-93
Набережные Челны (8552)20-53-41
Нижний Новгород (831)429-08-12
Новокузнецк (3843)20-46-81
Ноябрьск (3496)41-32-12
Новосибирск (383)227-86-73
Омск (3812)21-46-40
Орел (4862)44-53-42
Оренбург (3532)37-68-04
Пенза (8412)22-31-16
Петрозаводск (8142)55-98-37
Псков (8112)59-10-37
Пермь (342)205-81-47

Ростов-на-Дону (863)308-18-15
Рязань (4912)46-61-64
Самара (846)206-03-16
Санкт-Петербург (812)309-46-40
Саратов (845)249-38-78
Севастополь (8692)22-31-93
Саранск (8342)22-96-24
Симферополь (3652)67-13-56
Смоленск (4812)29-41-54
Сочи (862)225-72-31
Ставрополь (8652)20-65-13
Сургут (3462)77-98-35
Сыктывкар (8212)25-95-17
Тамбов (4752)50-40-97
Тверь (4822)63-31-35

Тольятти (8482)63-91-07
Томск (3822)98-41-53
Тула (4872)33-79-87
Тюмень (3452)66-21-18
Ульяновск (8422)24-23-59
Улан-Удэ (3012)59-97-51
Уфа (347)229-48-12
Хабаровск (4212)92-98-04
Чебоксары (8352)28-53-07
Челябинск (351)202-03-61
Череповец (8202)49-02-64
Чита (3022)38-34-83
Якутск (4112)23-90-97
Ярославль (4852)69-52-93