

Алматы (7273)495-231
Ангарск (3955)60-70-56
Архангельск (8182)63-90-72
Астрахань (8512)99-46-04
Барнаул (3852)73-04-60
Белгород (4722)40-23-64
Благовещенск (4162)22-76-07
Брянск (4832)59-03-52
Владивосток (423)249-28-31
Владикавказ (8672)28-90-48
Владимир (4922)49-43-18
Волгоград (844)278-03-48
Вологда (8172)26-41-59
Воронеж (473)204-51-73
Екатеринбург (343)384-55-89

Иваново (4932)77-34-06
Ижевск (3412)26-03-58
Иркутск (395)279-98-48
Казань (843)206-01-48
Калининград (4012)72-03-81
Калуга (4842)92-23-67
Кемерово (3842)65-04-62
Киров (8332)68-02-04
Коломна (4966)23-41-49
Кострома (4942)77-07-48
Краснодар (861)203-40-90
Красноярск (391)204-63-61
Курск (4712)77-13-04
Курган (3522)50-90-47
Липецк (4742)52-20-81

Магнитогорск (3519)55-03-13
Москва (495)268-04-70
Мурманск (8152)59-64-93
Набережные Челны (8552)20-53-41
Нижегород (831)429-08-12
Новокузнецк (3843)20-46-81
Ноябрьск (3496)41-32-12
Новосибирск (383)227-86-73
Омск (3812)21-46-40
Орел (4862)44-53-42
Оренбург (3532)37-68-04
Пенза (8412)22-31-16
Петрозаводск (8142)55-98-37
Псков (8112)59-10-37
Пермь (342)205-81-47

Ростов-на-Дону (863)308-18-15
Рязань (4912)46-61-64
Самара (846)206-03-16
Санкт-Петербург (812)309-46-40
Саратов (845)249-38-78
Севастополь (8692)22-31-93
Саранск (8342)22-96-24
Симферополь (3652)67-13-56
Смоленск (4812)29-41-54
Сочи (862)225-72-31
Ставрополь (8652)20-65-13
Сургут (3462)77-98-35
Сыктывкар (8212)25-95-17
Тамбов (4752)50-40-97
Тверь (4822)63-31-35

Тольятти (8482)63-91-07
Томск (3822)98-41-53
Тула (4872)33-79-87
Тюмень (3452)66-21-18
Ульяновск (8422)24-23-59
Улан-Удэ (3012)59-97-51
Уфа (347)229-48-12
Хабаровск (4212)92-98-04
Чебоксары (8352)28-53-07
Челябинск (351)202-03-61
Череповец (8202)49-02-64
Чита (3022)38-34-83
Якутск (4112)23-90-97
Ярославль (4852)69-52-93

Россия +7(495)268-04-70

Казахстан +7(7172)727-132

Киргизия +996(312)96-26-47

<https://amiad.nt-rt.ru> || afv@nt-rt.ru

AMIAD WATER SYSTEMS Ltd.

AMIAD 100mm (4") Super and 150mm (6") Compact Brushaway Filters

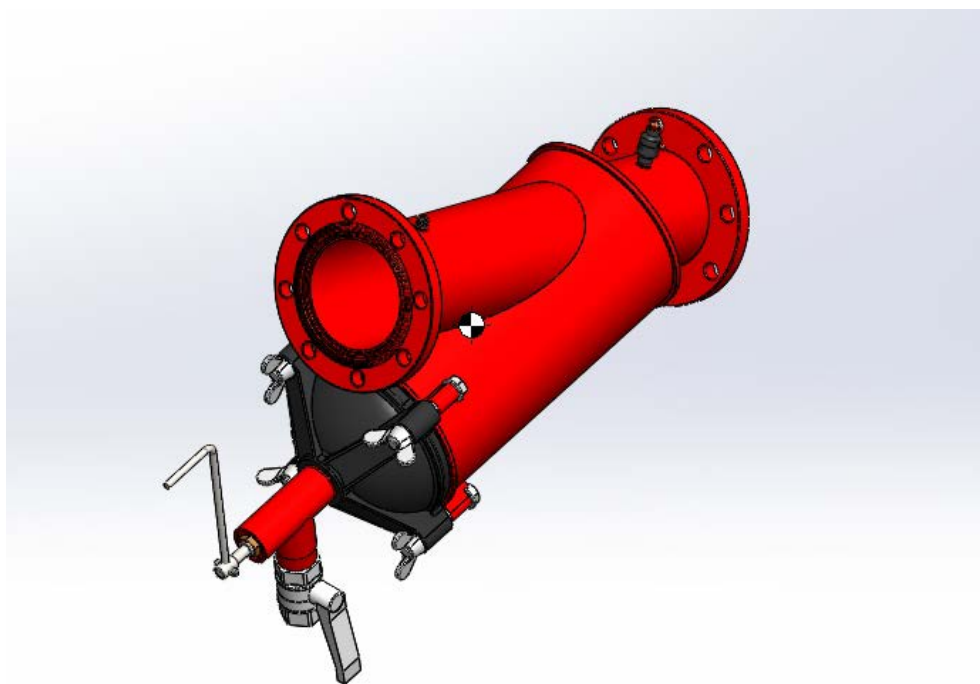

Installation and Maintenance Instructions

Disclaimer:

Copyright © 2017 Amiad Water Systems Ltd. All rights reserved.

The contents of this document, including without limitation all information and materials, images, illustrations, data, drawings, names and any other such materials that appear in this document are the sole property of Amiad Water Systems Ltd., including any intellectual property rights, whether registered or not, and all know-how contained or embodied therein. Amiad may alter, remove or change the Content without any further notice. You may not reproduce, copy, modify, create derivative works from, sell or participate in any sale of, or exploit in any way, in whole or in part, any of this document or its content.

This document does not replace any certified drawing, procedure or information provided by Amiad in reference to a specific customer, site or project.

Amiad assumes that all users understand risks involved within this file and/or its attached materials. This document is given in good faith and is not intended to impose any obligation to Amiad. While every effort has been made to ensure the information in this manual is accurate and complete, we would appreciate if you can bring any errors or omissions to the knowledge of Amiad or consult Amiad experts or its authorized representatives if you have any questions.

SAFETY INSTRUCTIONS

General

1. Prior to installation or any treatment given to the filter, read carefully the installation and operation instructions.
2. While treating the filter all conventional safety instructions should be observed in order to avoid danger to the workers, the public or to property in the vicinity.
3. No changes or modification to the equipment are permitted without a written notification given by the manufacturer or by its representative, on the manufacturer behalf.

Installation

1. Install the filter according to the installation instructions detailed in this manual.
2. Make sure to leave enough clearance to enable easy access for future treatments and safe maintenance operations.
3. Extra safety devices should be installed on hot water applications to avoid skin burn danger.

Operation and Maintenance

1. Loosening or unscrewing bolts should be done only after the pressure in the filter had been released.
3. Avoid splashing and water leaking to minimize slipping danger or damage to the equipment caused by moisture.
4. Always open and close valves slowly and gradually.
5. Remove grease and fat material residues in order to avoid slipping.
6. After treatment has been completed, re-assemble the protection covers.
7. Manual cleaning of filter element using high water pressure or steam should be performed in accordance with the cleaning system instructions and without endangering the operator or his vicinity.
8. Manual cleaning of filter element using acid or other chemical agents should be performed in accordance with the relevant material safety instructions and without endangering the operator or his vicinity.

Use of Lifting Equipment

1. While using lifting equipment, make sure that the filter or the lifted part is chained securely and in a safe manner.
2. Do not leave lifted equipment if there is no necessity. Avoid working below lifted equipment.
3. Wear a safety helmet while using lifting equipment.

PRINCIPLE OF OPERATION

The Amiad series of semi-automatic filters trap dirt from water as it flows through a perforated or a weave-wire stainless steel filtration element. Filtration elements are available for various filtration degrees and are color-coded for convenient identification.

Water flows through the filter element from the inside out, so that dirt accumulates on the inner surface of the filtration element. The direction of flow is indicated by an arrow on the filter housing.

The Brushaway filters provide an excellent method of manually cleaning the filter screen without removing the screen itself. The cleaning process is based on mechanical wiping of the inner surface of the screen element and flushing the wiped debris from the filter housing by opening the flush valve.

This document is the Installation, Operation and Maintenance manual of the 4"S and the 6"C Brushaway filters.

INSTALLATION

Installation Site design recommendations

1. Select a convenient location for the installation of the filter where operation and maintenance will be optimal.
2. Refer to the drawing on page 4 for a typical installation drawing.
3. Isolation valves are needed in order to isolate filter during maintenance or repair.
4. Design the installation according to the correct direction of flow as indicated by an arrow on the filter housing.
5. Take care to leave enough room to remove the filter element for cleaning or service.
6. It is recommended that the filter housing be situated in 45° downwards or in a horizontal orientation.

Installation instructions

1. Install the filter on suitable foundations. Make sure to bolt it and anchored it properly. Ensure the direction of flow according to the arrow marked on the filter housing.
2. Prior to installing the filter, flush the main line at the connection point thoroughly in order to remove large objects that may damage the filter's internal mechanism.
3. Arrange for suitable lighting at the area of the filter to enable good visibility and safe maintenance.
4. Arrange suitable platforms and safety barriers to enable easy access to the filter without climbing on pipes and other equipment.
5. Install a non-return valve on the filter outlet port for protecting the filter from back flow or pressure surge.

IMPORTANT!!

Installation of a Non-return Valve protects your filter from static backpressure and dangerous reverse flow!

TYPICAL INSTALLATION*

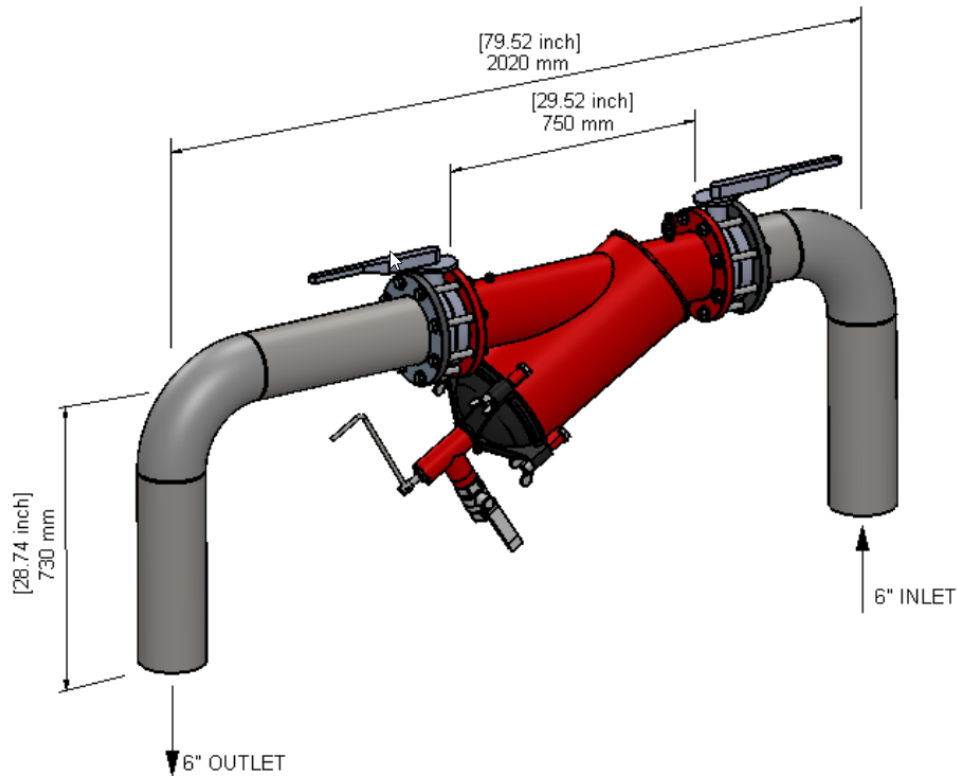

* Dimensions refer to 6" C filter

Operation instructions:

1. Cleaning the filter must be done when pressure differential across the screen reaches 0.5-bar.
2. **Cleaning the Brushaway filter must be done while the filter is under pressure.**
3. Open the flushing valve gradually.
4. Turn the handle clockwise a few times.
5. Close the valve gradually.
6. In case that the filter is still clogged, repeat the above while the downstream valve of the filter is closed.

In most cases, this will clean the screen. However, if necessary, close the upstream valve, drain the filter and clean it manually.

Maintenance:

1. Check that the filter operates properly, following a general inspection.
2. If necessary, take care of any leakage from the spindle shaft by replacing the internal O-ring seal (#17) and lubricating it with silicon grease.
3. In case of reduction in cleaning ability of the filter, remove the screen with the Brushaway mechanism and visually check the condition of the brushes. The brush bristles should be pressed against the screen. If the bristles do not touch the screen, they should be replaced.

PARTS SCHEDULE (Molded Screen)

No.	CAT. No.	Description	Qty	Material
1	710105-000155	METAL HOUSING 4"S IN-LINE ISO16 PKPK 3002 ST.37-2 POLYESTER	1	ST 37-2
1	710105-000153	METAL HOUSING 4"S IN-LINE BSTD PKPK 3002 ST.37-2 POLYESTER	1	ST 37-2
1	710105-000154	METAL HOUSING 4"S IN-LINE ASA150 PKPK 3002 ST.37-2 POLYESTER	1	ST 37-2
1	710105-000196	METAL HOUSING 6"C IN-LINE JAD PKPK 3002 ST.37-2 POLYESTER	1	ST 37-2
1	710105-000195	METAL HOUSING 6"C IN-LINE BSTD PKPK 3002 ST.37-2 POLYESTER	1	ST 37-2
2	710103-000679	LID 6"-14" 8" METAL POLYESTER W/2"THR	1	PE-100
3	770104-000089	HYDRAULIC SEAL NBR 45 SHORE POLYESTER LID STEEL FILTER	1	NBR
4	710103-000591	NIPPLE 1/4" 2" METAL BRASS BSPT	2	Brass
5	700190-001305	PRESSURE CHECK POINT (PLASTIC) W/O NIPPLE	1	Various
6	760101-000297	HEX BOLT PARTIAL THRD 3/4"UNC 5 1/4" C/ST ASME B18.2.1 Z. PLATED	4	Z. Plated C/ST
7	760103-000070	FLAT WASHER M20 DIN125 C/ST ZINC PLATED	4	Z. Plated C/ST
8	760102-000076	WING NUT 3/4"UNC C/ST ZINC PLATED B18.17	4	Z. Plated C/ST
9	700101-000489	MOLDED WEAVEWIRE SCREEN S/ST316L 2740SQ.CM 130MIC 6" METAL	1	Various
9.1	770104-000080	HYDRAULIC SEAL EPDM YELLOW DOT 70 SHORE SCREEN STEEL FILTER	2	EPDM
10	710102-000219	OPERATING HANDLE S/ST316L F/4"-14" BRUSHAWAY	1	S/ST 316L
11	710103-000740	TIGHTENING NUT 6" METAL SEMI-AUTO BRASS NUT 4"S-14"BRUSH	1	Brass
12	710103-000739	BUSHING 6" METAL SEMI-AUTO DELRIN F/4"S-14"	1	Delrin
13	710102-000130	2" T CONNECTOR C/ST BSPT BRUSHAWAY RED	1	ST. 37-2
13	710102-000132	2" T CONNECTOR C/ST NPT BRUSHAWAY RED	1	ST. 37-2
14	730104-000265	2-WAY BALL VALVE 2" F/F BRASS MANUAL BSP	1	Nickel Coated
14	730104-000268	2-WAY BALL VALVE 2" F/F BRASS MANUAL NPT	1	Nickel Coated
15	760101-000447	HEX BOLT FULL THRD M6 35MM S/ST304 DIN933	1	S/ST 304
16	760103-000109	SPRING WASHER M6 DIN127 S/ST316	1	S/ST 316
17	760107-000053	LOCK SPRING SHAFT STEEL FILTERS S/ST316L DW	1	S/ST 316L
18	700190-001363	SEALING ROPE SET 4MM L-1779	1	PTFE
19	780101-000975	NUT 3/4" THREADED PP PLASSON	1	PP
20	710101-000974	FERTILIZERS CLIP PBT BLACK	1	PBT
21	760103-000094	FLAT WASHER M6 DIN125 S/ST316	2	S/ST 316
22	700190-001245	CLOGGING INDICATOR	1	Various
23	710103-000777	BUSHING 4"-14" 8" METAL SEMI-AUTO DELRIN GUIDE BRUSH AXIS	1	Delrin
24	700190-001441	BRUSH ASSEMBLY 4"S/6"C FOR MLD SCREEN	1	Various
24.1	760102-000085	HEX NUT M6 S/ST316 DIN934 DW	5	S/ST 316
24.2	710102-000217	4"S SPINDLE+FRAME S/ST316L BRUSHAWAY F/MOLDED SCREEN	1	S/ST 316L
24.3	710103-000749	BRUSH 260MM 8" METAL SEMI-AUTO PLASTIC UNIT F/MOLDED SCREEN	2	PVC
24.4	760101-000445	HEX BOLT FULL THRD M6 25MM S/ST316 DIN933 DW	4	S/ST 316

PARTS DRAWING (Molded Screen)

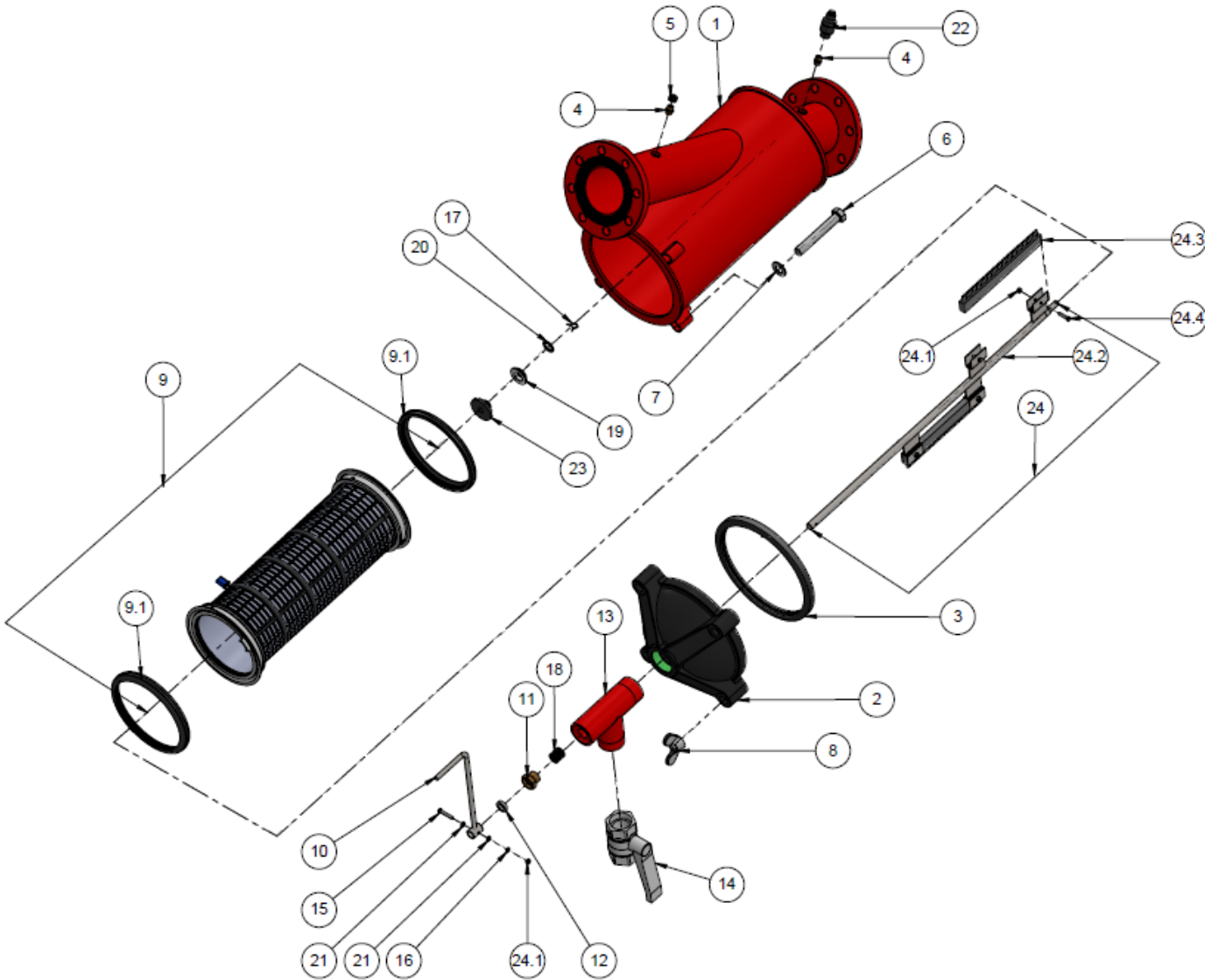

PARTS SCHEDULE (Perforated Screen)

No.	CAT. No.	Description	Qty	Material
1	710105-000155	METAL HOUSING 4"S IN-LINE ISO16 PKPK 3002 ST.37-2 POLYESTER	1	ST 37-2
1	710105-000153	METAL HOUSING 4"S IN-LINE BSTD PKPK 3002 ST.37-2 POLYESTER	1	ST 37-2
1	710105-000154	METAL HOUSING 4"S IN-LINE ASA150 PKPK 3002 ST.37-2 POLYESTER	1	ST 37-2
1	710105-000196	METAL HOUSING 6"C IN-LINE JAD PKPK 3002 ST.37-2 POLYESTER	1	ST 37-2
1	710105-000195	METAL HOUSING 6"C IN-LINE BSTD PKPK 3002 ST.37-2 POLYESTER	1	ST 37-2
2	710103-000679	LID 6"-14" 8" METAL POLYESTER W/2"THR	1	PE-100
3	770104-000089	HYDRAULIC SEAL NBR 45 SHORE POLYESTER LID STEEL FILTER	1	NBR
4	710103-000591	NIPPLE 1/4" 2" METAL BRASS BSPT	2	Brass
5	700190-001305	PRESSURE CHECK POINT (PLASTIC) W/O NIPPLE	1	Various
6	760101-000297	HEX BOLT PARTIAL THRD 3/4"UNC 5 1/4" C/ST ASME B18.2.1 Z. PLATED	4	Z. Plated C/ST
7	760103-000070	FLAT WASHER M20 DIN125 C/ST ZINC PLATED	4	Z. Plated C/ST
8	760102-000076	WING NUT 3/4"UNC C/ST ZINC PLATED B18.17	4	Z. Plated C/ST
9	700101-000482	PERFORATED SCREEN S/ST316L 2740SQ.CM 1500MIC 6" METAL	1	Various
9.1	770104-000080	HYDRAULIC SEAL EPDM YELLOW DOT 70 SHORE SCREEN STEEL FILTER	2	EPDM
10	710102-000219	OPERATING HANDLE S/ST316L F/4"-14" BRUSHAWAY	1	S/ST 316L
11	710103-000740	TIGHTENING NUT 6" METAL SEMI-AUTO BRASS NUT 4"S-14"BRUSH	1	Brass
12	710103-000739	BUSHING 6" METAL SEMI-AUTO DELRIN F/4"S-14"	1	Delrin
13	710102-000130	2" T CONNECTOR C/ST BSPT BRUSHAWAY RED	1	ST. 37-2
13	710102-000132	2" T CONNECTOR C/ST NPT BRUSHAWAY RED	1	ST. 37-2
14	730104-000265	2-WAY BALL VALVE 2" F/F BRASS MANUAL BSP	1	Nickel Coated
14	730104-000268	2-WAY BALL VALVE 2" F/F BRASS MANUAL NPT	1	Nickel Coated
15	760101-000447	HEX BOLT FULL THRD M6 35MM S/ST304 DIN933	1	S/ST 304
16	760103-000109	SPRING WASHER M6 DIN127 S/ST316	1	S/ST 316
17	760107-000053	LOCK SPRING SHAFT STEEL FILTERS S/ST316L DW	1	S/ST 316L
18	700190-001363	SEALING ROPE SET 4MM L-1779	1	PTFE
19	760103-000094	FLAT WASHER M6 DIN125 S/ST316	2	S/ST 316
20	710103-000735	CENTER.RING 6"MTL S. AUTO DELRIN INSERT	1	POM
21	710102-000163	8" CENTERING RING S/ST316L	1	S/ST 316L
22	700190-001245	CLOGGING INDICATOR	1	Various
23	700190-001438	BRUSH ASSEMBLY 4"S/6"C 194 F/PERF	1	Various
23.1	760102-000085	HEX NUT M6 S/ST316 DIN934 DW	4	S/ST 316
23.2	760101-000445	HEX BOLT FULL THRD M6 25MM S/ST316 DIN933 DW	3	S/ST 316
23.3	710102-000215	4"S SPINDLE+FRAME S/ST316L BRUSHAWAY	1	S/ST 316L
23.4	710103-000732	BRUSH 435MM 6" METAL SEMI-AUTO PVC UNIT	1	Various

PARTS DRAWING (Perforated Screen)

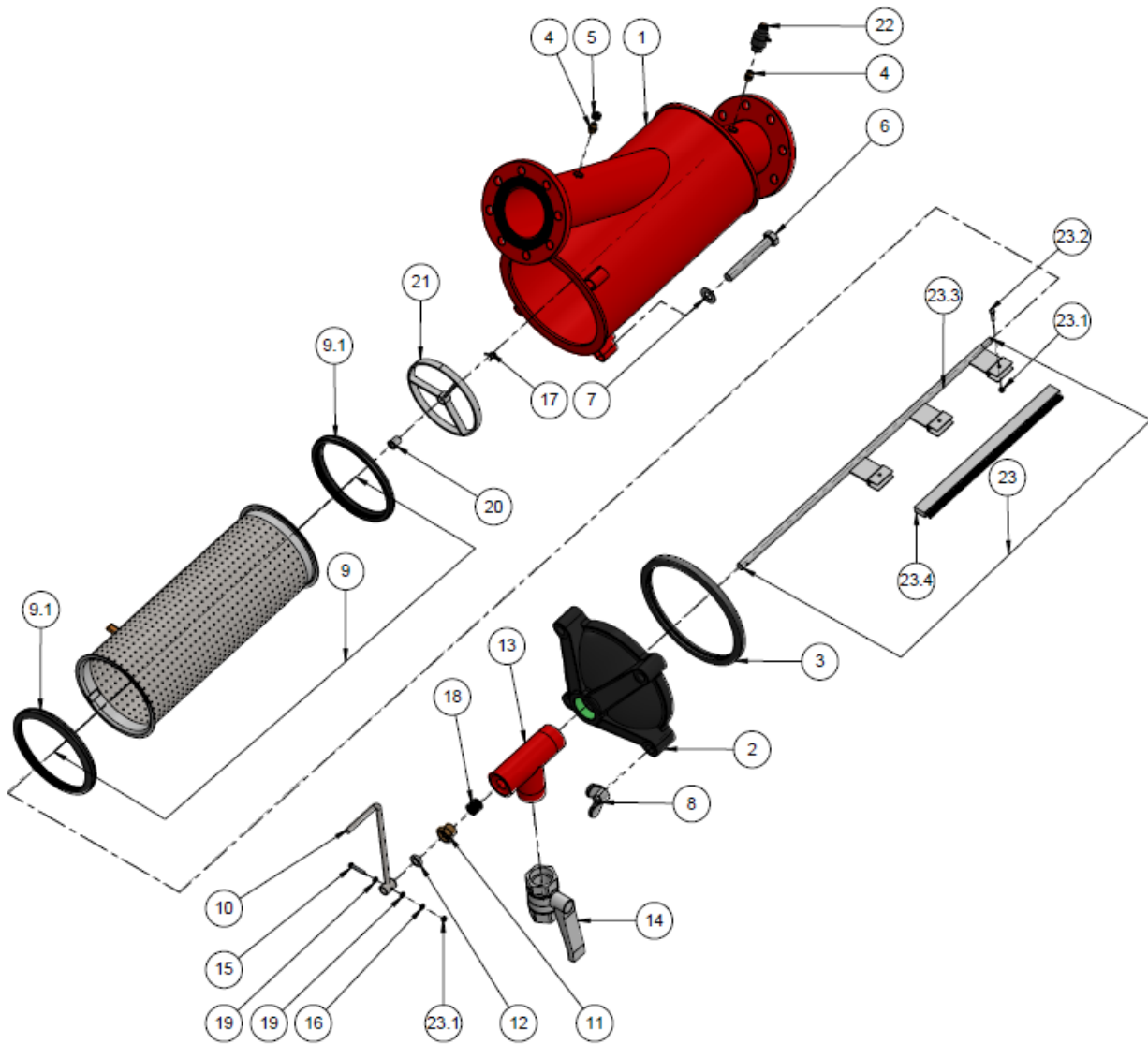

Amiad Limited Warranty

This certificate applies to Amiad Products purchased by You from Amiad or an Amiad authorized Distributor (“Distributor”). This limited warranty extends only to the original purchaser, and is not transferable to anyone who subsequently purchases, leases, or otherwise obtains the Product from the original purchaser.

1. Amiad hereby warrants that the Products are and will be free from defects in material and workmanship under normal use and service. Amiad warrants that it will correct manufacturing defects in the Products, in accordance with the conditions set out in this warranty.
2. This warranty is enforceable for a period of 12 months after the date Bill of Lading or equivalent (the “Warranty Period”).
3. In the event that during the Warranty Period the Distributor discovers a defect in material and/or workmanship in any Product or part (the “Defective Product”), it shall submit a written complaint to Amiad using Amiad’s standard customer complaint form. For the receipt of the customer complaint form, the submission of the complaint or any questions please contact your customer service representative.
4. Upon written demand by Amiad the Distributor shall return the Defective Products – or a sample thereof – to Amiad, at Amiad’s cost. If the customer ships any such Product, Amiad suggests the customer package it securely and insure it for value, as Amiad assumes no liability for any loss or damage occurring during shipment. Provided however that in the event Amiad determines that the warranty does not apply to such Product, Distributor shall promptly reimburse Amiad for such cost (including freight and customs). Any returned Product or part must be accompanied by the warranty certificate and the purchase invoice. It is clarified that the Distributor may not return the Defective Product unless such return was coordinate and approved by Amiad in advance.
5. Amiad’s obligation under this warranty shall be limited to, at its option, the repair or exchange, free of charge, of the Product or any part which may prove defective under normal use and service during the Warranty Period. The provision of a repaired or replacement Product during the Warranty Period will result in an extension of the Warranty Period by an additional period of 12 months, provided that the total accumulated Warranty Period shall in any event be no more than 18 months from the original Bill of Lading.
6. This warranty is valid on the condition that the Products are installed according to Amiad’s instructions as expressed in Amiad’s instruction manuals and according to the technical limitations as stipulated in Amiad’s literature or as stated by a representative of Amiad.
7. This warranty will not apply to damaged or defective Products resulting from or related to:
 - (i) Fire, flood, power surges or failures or any other catastrophe/and or unforeseen occurrence, such as but not limited to those for which the customers are customarily insured;
 - (ii) Fault, abuse or negligence of the customer;
 - (iii) Customer’s responsibilities, including the failure of the intake water to meet the agreed standards, as set forth in a written document, approved by Amiad or improper storage.
 - (iv) Improper or unauthorized use of the Product or related parts by the customer, including the customer’s failure to operate the Product in conformity with the recommendations and instructions of Amiad, as set forth in Amiad’s manuals and other written materials, the operation of the Product other than by a trained and qualified operator, or improper installation of the Product by a third party not authorized by Amiad;
 - (v) Performance by the customer of maintenance and other services other than by a trained and qualified advanced operator, or other than in conformity with the recommendations and instructions of Amiad, or other than in accordance with procedures defined in the literature supplied for Products;
 - (vi) Any alteration, modification foreign attachment to or repair of the Products, other than by Amiad or its authorized technical representatives.
8. In no event shall Amiad be liable to the customer or any third party for any damages, including indirect, special, exemplary, punitive or consequential damages, or lost profits arising out of or in connection with this warranty, or arising out of or in connection with the Product’s performance or failure to perform, even if it has been advised of the possibility of such damages.
9. Amiad will be excused for failure to perform or for delay in performance hereunder if such failure or delay is due to causes beyond its reasonable control or force majeure preventing or hindering performance.
10. The limited warranty set forth herein is the only warranty given by Amiad and is provided in lieu of any other warranties created by any documentation, packaging or otherwise.
11. Amiad makes no warranty whatsoever in respect of accessories or parts not supplied by Amiad. In the event that Amiad is required to correct a defective Product or product not covered by this warranty, it will do so solely in consideration for additional fees.

Алматы (7273)495-231
Ангарск (3955)60-70-56
Архангельск (8182)63-90-72
Астрахань (8512)99-46-04
Барнаул (3852)73-04-60
Белгород (4722)40-23-64
Благовещенск (4162)22-76-07
Брянск (4832)59-03-52
Владивосток (423)249-28-31
Владикавказ (8672)28-90-48
Владимир (4922)49-43-18
Волгоград (844)278-03-48
Вологда (8172)26-41-59
Воронеж (473)204-51-73
Екатеринбург (343)384-55-89

Иваново (4932)77-34-06
Ижевск (3412)26-03-58
Иркутск (395)279-98-48
Казань (843)206-01-48
Калининград (4012)72-03-81
Калуга (4842)92-23-67
Кемерово (3842)65-04-62
Киров (8332)68-02-04
Коломна (4966)23-41-49
Кострома (4942)77-07-48
Краснодар (861)203-40-90
Красноярск (391)204-63-61
Курск (4712)77-13-04
Курган (3522)50-90-47
Липецк (4742)52-20-81

Магнитогорск (3519)55-03-13
Москва (495)268-04-70
Мурманск (8152)59-64-93
Набережные Челны (8552)20-53-41
Нижегород (831)429-08-12
Новокузнецк (3843)20-46-81
Ноябрьск (3496)41-32-12
Новосибирск (383)227-86-73
Омск (3812)21-46-40
Орел (4862)44-53-42
Оренбург (3532)37-68-04
Пенза (8412)22-31-16
Петрозаводск (8142)55-98-37
Псков (8112)59-10-37
Пермь (342)205-81-47

Ростов-на-Дону (863)308-18-15
Рязань (4912)46-61-64
Самара (846)206-03-16
Санкт-Петербург (812)309-46-40
Саратов (845)249-38-78
Севастополь (8692)22-31-93
Саранск (8342)22-96-24
Симферополь (3652)67-13-56
Смоленск (4812)29-41-54
Сочи (862)225-72-31
Ставрополь (8652)20-65-13
Сургут (3462)77-98-35
Сыктывкар (8212)25-95-17
Тамбов (4752)50-40-97
Тверь (4822)63-31-35

Тольятти (8482)63-91-07
Томск (3822)98-41-53
Тула (4872)33-79-87
Тюмень (3452)66-21-18
Ульяновск (8422)24-23-59
Улан-Удэ (3012)59-97-51
Уфа (347)229-48-12
Хабаровск (4212)92-98-04
Чебоксары (8352)28-53-07
Челябинск (351)202-03-61
Череповец (8202)49-02-64
Чита (3022)38-34-83
Якутск (4112)23-90-97
Ярославль (4852)69-52-93

Россия +7(495)268-04-70

Казахстан +7(7172)727-132

Киргизия +996(312)96-26-47

<https://amiad.nt-rt.ru> || afv@nt-rt.ru